

**B**



**MAXXTRON**

**HIGH SPEED BRIDGE TYPE  
MACHINING CENTER**



**MAXXTRON TECHNOLOGY CO., LTD.**

No.20, Ln.750, Wangfu St., Wangtian Vil., Dadu Dist.,  
Taichung City 432, Taiwan(R.O.C.)

Tel: 886-4-26931373

Fax: 886-4-26931298

Http: //www.maxxtron.com.tw

E-mail: sales@maxxtron.com.tw



[www.maxxtron.com.tw](http://www.maxxtron.com.tw)



[sales@maxxtron.com.tw](mailto:sales@maxxtron.com.tw)

Agent:

**B7, B11, B14, B17, B20,  
B25/B25T, B35/B35T, B45/B45T**



B14



B17



B11



B20

## PERFECT COMBINATION OF MECHANICAL AND AESTHETIC

- ▲ Mechanical and aesthetic combination of minimalist design concept with user friendly and practicality.
- ▲ Bidirectional machine door open design makes loading and unloading space maximization, effectively reducing the interference caused due to the problem of loading and unloading parts.
- ▲ Improved operation box, according to different user habits, adjusted operating position and angle.
- ▲ Pneumatic and hydraulic movable storage unit, effectively use of the machine space, reducing space costs and maintenance convenience features.

**PRODUCTION LINE**

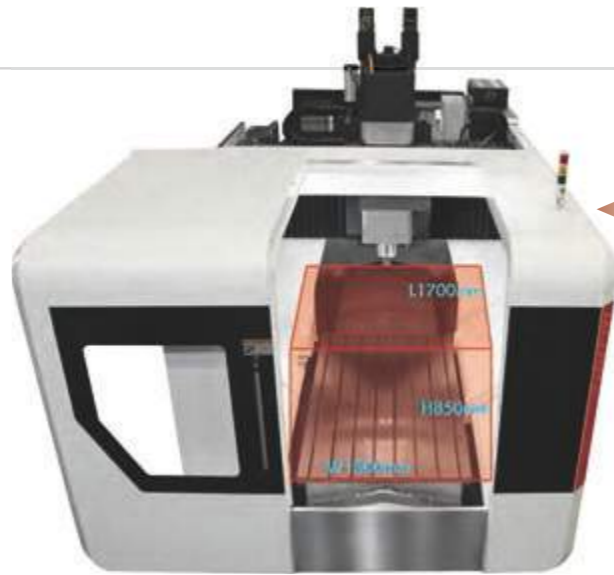

B17 Machining space  
W1300mm / L1700mm / H850mm



B11 Machining space  
W1050mm / L700mm / H400mm

**ULTRA MACHINING SPACE**

- ▲ B series is designed for the Mold & Die industry, with ultra-large working space than other competitor.
- ▲ Ultra working space can easy handling.

**DUAL DOOR DUAL PROTECTION**



- ▲ Electric control box is divided into controller and I/O layer, reduce heating and decrease temperature efficiently.
- ▲ Needless to open the controller layer when I/O is in maintenance, in order to reduce the pollution. The dustproof rubber strips are used all around for pollution isolation.

**EXCELLENT OPERATION DESIGN**

- ▲ Front door fully open 1400mm (B17/B20), the workpiece can be hung by crane, no interference.
- ▲ Side door and the bed height 1000mm, workpiece and the operator for easy observing cutting situation.
- ▲ Indication light bar, obviously indication the status of machine, keep watching of the machine situation.
- ▲ Excellent arc machine cover design, reduce floor space and cost.

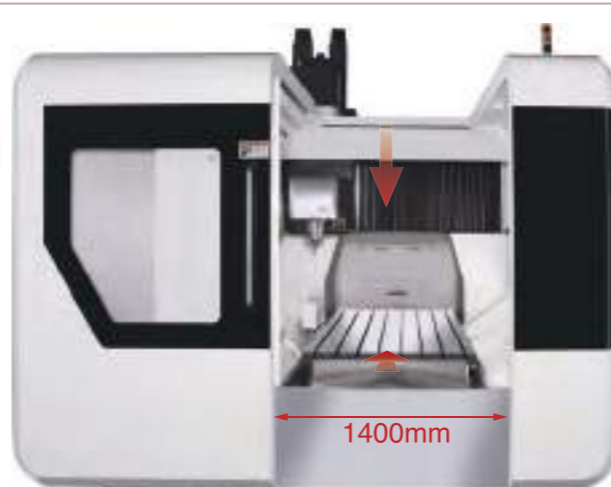

B17/B20 Front door fully open 1400mm  
Side door and bed height 1000 mm

Quick-easy-handling  
Easy loading and unloading working-piece  
Minimization floor space design

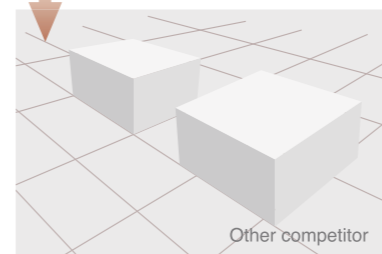

## OPTIMAL STRUCTURE DESIGN

▲ Option: Z axes travel 1100mm

B series is new generation design ed for the machining requirements from the and industries of parts product ion and Mold & Die.

- ▲ 3 axes are equipped with high prec ision roller type linear guide ways to meet the demand of high acceleration an d deceleration, the maximum feed rate ups to 30m/min. By adopting 15000~24 000 rpm high speed spindles, B series is widely used in the industries of 3C, automotive and mold machining.
- ▲ The swivel operation panel allows operate with any angle and position.
- ▲ The wider space of door opening m akes workpiece easier to be loaded and unloaded.

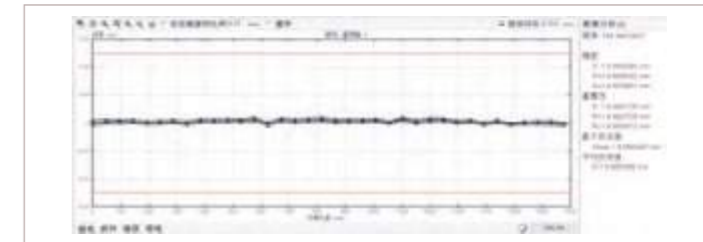

Axes of Laser measurement VDI



XY-F3000 ballbar diagnosis

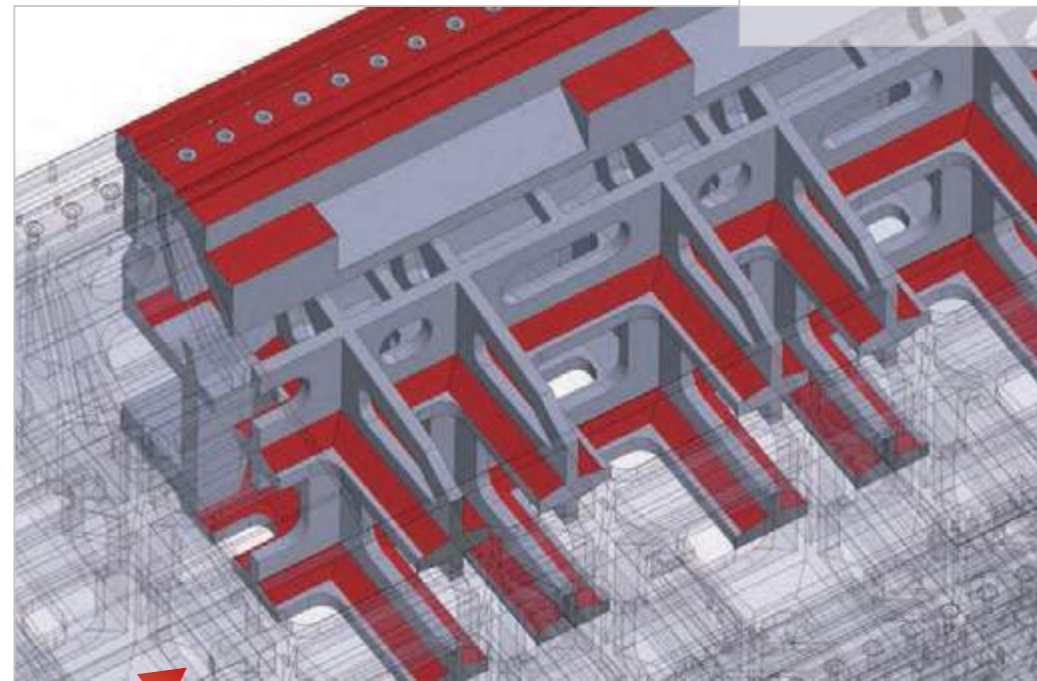

## ALL CASTING RIGIDITY CONSOLIDATE

- ▲ High precision grinding on working table, assure the basis of the machine precision and reliably. And has a wide range of processing and load capacity.
- ▲ 8 guide blocks under table ensure the consistent precision of consecutive operation.
- ▲ High chip removal design.
- ▲ Cast iron through state-of-the-art technology.



## DYNAMIC/STATIC RIGIDITY OPTIMUM DESIGN

- ▲ All of 3 axes are equipped with high precision roller type linear guide ways to optimize acceleration/deceleration. And match the high speed, accuracy and performance manufacturing requirements.
- ▲ Extra rigidity Column design:  
The unique design of the column structure is more stability than other comparable models, and beam & column are made of one piece casting provides the best rigidity and stability.
- ▲ The saddle structure design:  
The ladder type design of linear guide ways on the beam provide wider supporting surface for saddle, assuring the spindle of a powerful and stable cutting performance. Fully symmetrical design and perfect thermal equilibrium structural design, reduce high speed thermal deformation, so that the machine body structure can maintain high stability.

- ▲ Adopts high precision transmission's components to reach high speed, high precision and high efficiency manufacturing requirements.
- ▲ The use of certified metal cover strip to protect all the mounting holes, saving cost, ease of installation and the safe and dust-proof.
- ▲ Larger-Block to increase the load capacity and stability of movement between the linear guide and the block can be separated maintenance.

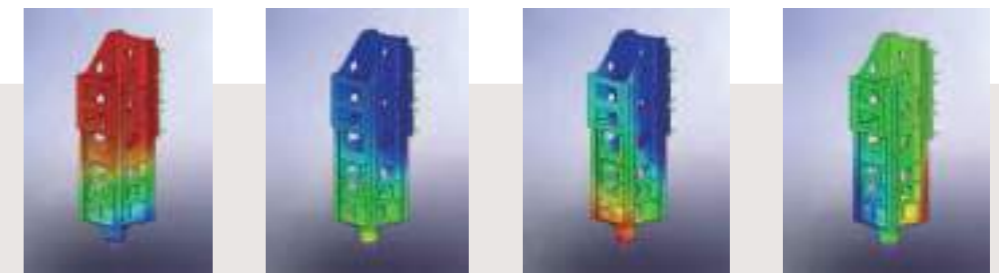

▲ Tool measurement device install on column makes high accuracy



▲ Wireless workpiece measurement, no cover issue

▲ Spindle shaft cooling

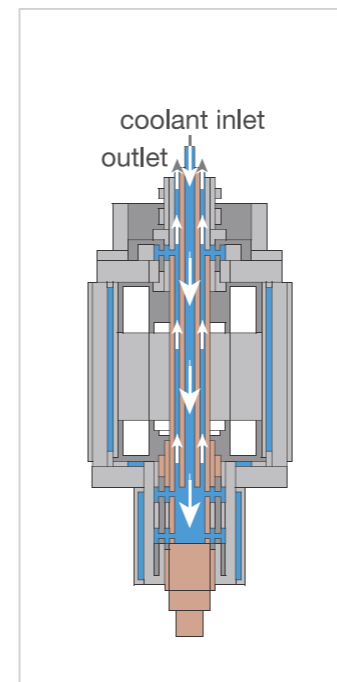

▲ DD motor

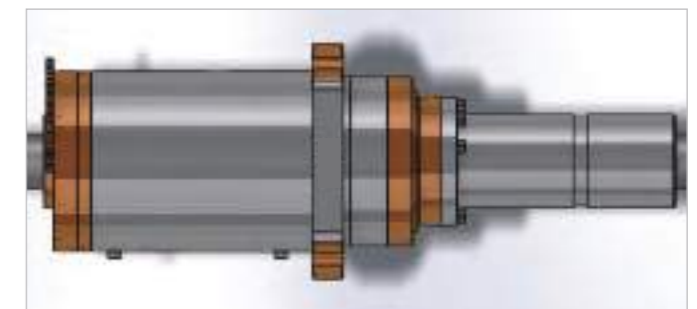

▲ Ballscrew hollow cooling and bearing cooling

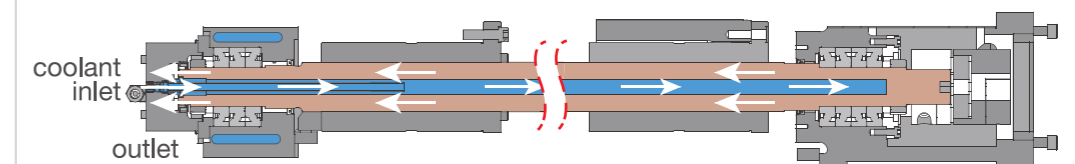

MACHINING FUNCTIONS AFC.HSC.ACC

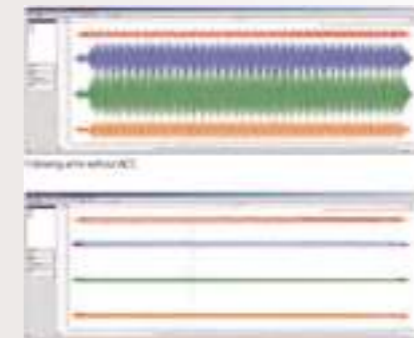
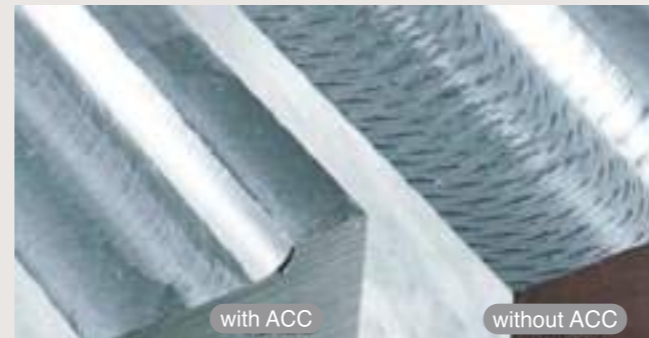
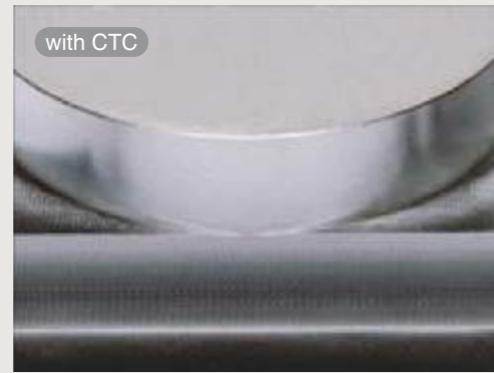
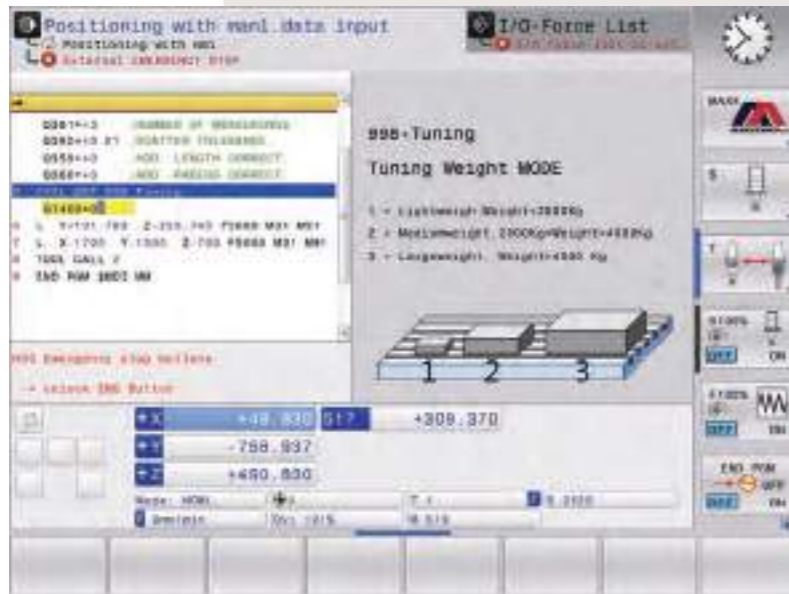

Dynamic collision monitor-DCM effective avoid collision of program or human error

CTC compensation of position errors at the tool centre point generated by acceleration forces.

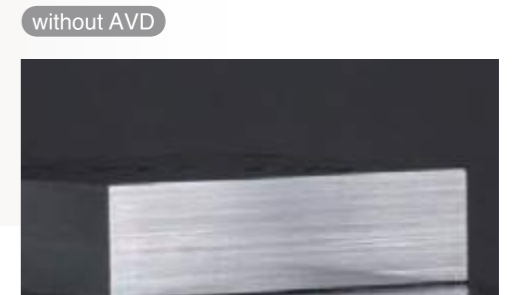
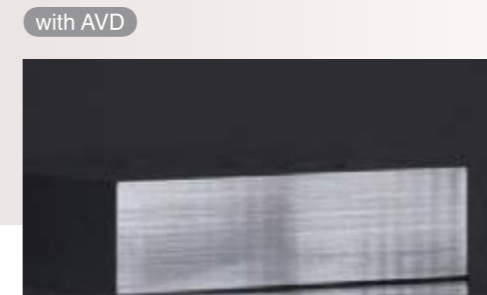

AVD reduce the level of machine vibration.



APPLICATION

FACE MILLING REMOVE RATE

**500**  
cc/min.

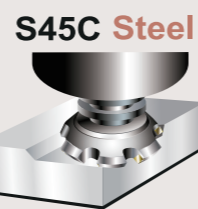

TOOL: 63mmX5T  
SPEED: 1,500rpm  
FEED: 10,000mm/min  
WIDTH: 50mm  
DEPTH: 1mm

FACE MILLING DEPTH

**3**  
mm



TOOL: 80mm X 6T  
SPEED: 1,500rpm  
FEED: 1,500mm/min  
WIDTH: 60mm  
RATE: 270cc/min

END MILLING DEPTH

**4**  
mm



TOOL: 32mm X 3T  
SPEED: 1,500rpm  
FEED: 675mm/min  
WIDTH: 25mm  
DEPTH: 4mm

DRILL TOOL DIA.

**Ø59**  
mm



TOOL: 59mm  
SPEED: 1,000rpm  
FEED: 70mm/min  
DEPTH: 100mm

B17 BBT50 / HSK-100A



Built-in type spindle(optional)  
22/69kW, 24000rpm

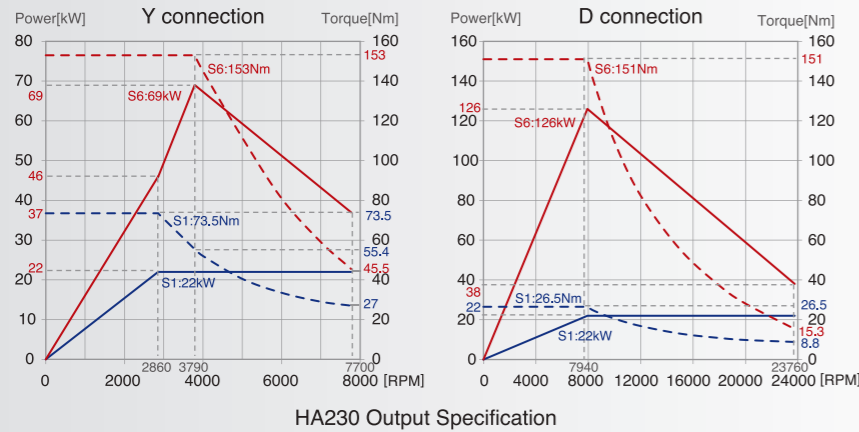

## SPINDLE

- ▲ B series provides direct-drive type & built-in type spindle to meet different machining requirements. The spindle speed ranges from 15,000rpm ~ 24,000rpm.
- ▲ Spindles are from the professional spindle manufacturers, featuring high accuracy and high performance.
- ▲ The built-in thermal compensation system (optional) decreases the effect of thermal variation, assuring the accuracy during operation.
- ▲ Large diameter spindle and high precision ceramic bearings (65mm) increase cutting rigidity and reduce the tool vibration.
- ▲ Spindle cooling system reduces thermal variation and prolongs working life of spindle.

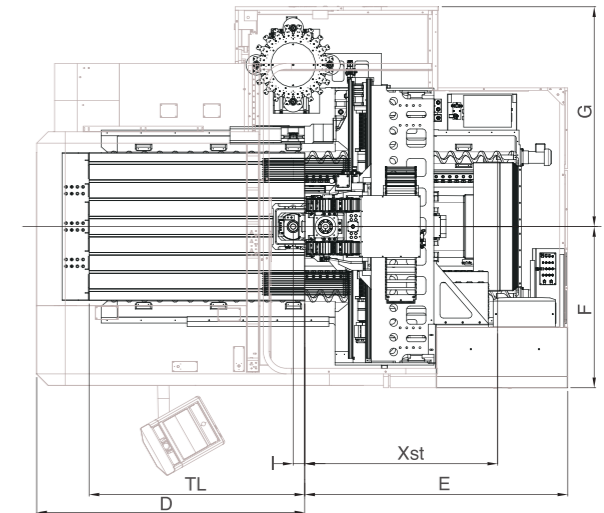

Built-in type spindle(standard)  
25/33kW, 24000rpm

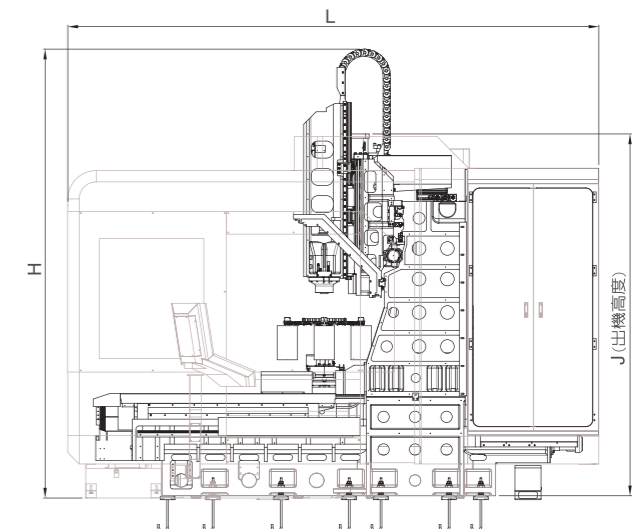
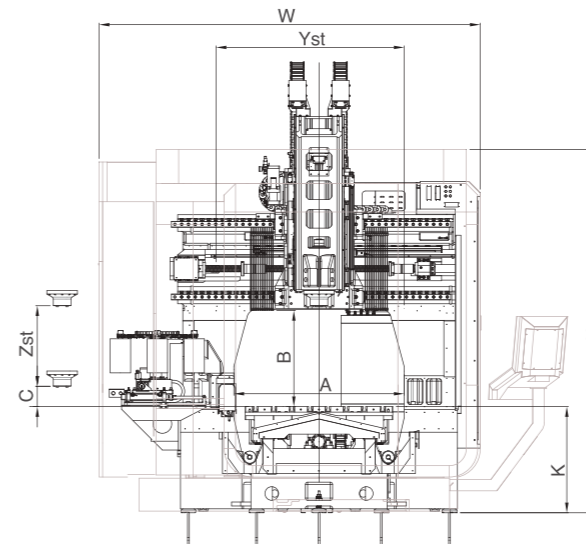
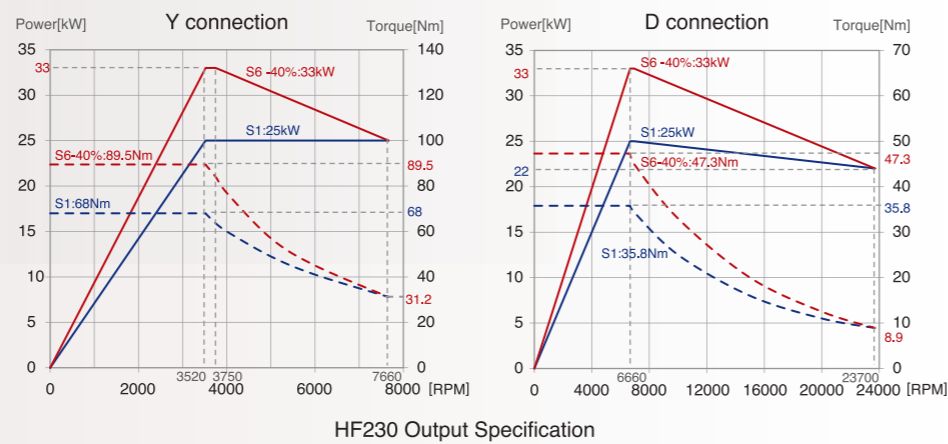

## ATC

ARMLESS TYPE(Standard)  
20T, HSK-A63/BT40  
12T/16T, HSK-A100/BT50



ARM TYPE(Optional) ▲  
30T/48T/60T, HSK-A63/BT40  
24T/32T/60T/90T, HSK-A100/BT50

	A	B+opt	C+opt	D	E	F	G	H/opt	H1+opt	I	J+opt	K	L	W	Xst	Yst	Zst	TW	TL
B7	720	600	100	1300	1500	950	1280	2850	2200	100	2300	795	2800	2230	700	1000	400	660	900
B11	1030	470	180	1050	1750	1100	1700	3250	2450	0	2340	795	2800	2800	700	1200	500	1050	700
B14	1120	640	150	2150	2100	1200	1850	3260	2520	100	2550	695	4260	3200	1400	1300	600	1000	1600
B17	1500	840	180	2360	2320	1420	1940	3960	3200	100	3210	935	4680	3360	1700	1500	700	1300	1900
B20	1500	840	180	2560	2520	1420	1940	3960	3200	100	3210	935	5020	3360	2000	1500	700	1300	2200
B25	1900	960	250	4000	3700	1800	3500	4350	3500	150	3620	1030	8700	5300	2500	2000	800	1700	2800
B25T	2300	960	250	4000	3700	2200	3900	4350	3500	150	3620	1030	8700	6100	2500	2400	800	2100	2800
B35	1900	960	250	5150	4850	1800	3500	4350	3500	150	3620	1030	11000	5300	3500	2000	800	1700	3800
B35T	2300	960	250	5150	4850	2200	3900	4350	3500	150	3620	1030	11000	6100	3500	2400	800	2100	3800
B45	1900	960	250	6300	6000	1800	3500	4350	3500	150	3620	1030	12300	5300	4500	2000	800	1700	4800
B45T	2300	960	250	6300	6000	2200	3900	4350	3500	150	3620	1030	12300	6100	4500	2400	800	2100	4800

## SPECIFICATIONS

TRAVEL	UNIT	B7	B11	B14	B17	B20	B25	B25T	B35	B35T	B45	B45T	
X axis	mm	700	1050	1400	1700	2000	2500	2500	3500	3500	4500	4500	
Y axis	mm	500	700	1000	1300	1300	1800	2200	1800	2200	1800	2200	
Z axis	mm	380	500	600	700/opt:1100		800/opt:1100		800/opt:1100		800/opt:1100		
Dist. from spindle nose to table	mm	100-480	180-680	150-750	180-880/opt:180-1280		250-1050/opt:180-1280		250-1050/opt:180-1280		250-1050/opt:180-1280		
Dist. between columns	mm	720	1080	1120	1500	1500	1850	2350	1850	2350	1850	2350	
<b>TABLE</b>													
Dimension	mm	750x600	1050x700	1600x1000	1900x1300	2200x1300	2800x1700	2800x2100	3800x1700	3800x2100	4800x1700	4800x2100	
Max. load	kg	500	800	3000	5000	5000	5000/opt:8000	5000/opt:8000	8000/opt:10000	8000/opt:10000	10000	10000	
T-Slot	mm	4x18HxP100	6x18HxP125	8x18HxP125	8x22HxP160	8x22HxP160	8x22HxP200	10x22HxP200	8x22HxP200	10x22HxP200	8x22HxP200	10x22HxP200	
<b>SPINDLE</b>													
Spindle Type		Build-in	Build-in Direct-drive	Build-in Direct-drive	Build-in Direct-drive	Build-in	Direct-drive	Build-in	Direct-drive	Build-in	Direct-drive	Build-in	Direct-drive
Spindle speed	rpm	30000	24000 15000	24000 12000	24000 12000	15000	10000/opt:12000/15000	15000	10000/opt:12000/15000	15000	10000/opt:12000/15000	15000	10000/opt:12000/15000
Spindle motor power (cont./30min rated)	kW	8.5/9	30/39 11/42	25/33 15/38	25/33 15/38	25/30	24.5/63	25/30	24.5/63	25/30	24.5/63	25/30	24.5/63
Spindle taper		HSK-40E	HSK-A63 DIN-40	HSK-A63 SK-40	HSK-A63 SK-40	BBT-50 / HSK-A100		BBT-50 / HSK-A100		BBT-50 / HSK-A100		BBT-50 / HSK-A100	
<b>FEEDRATE</b>													
Rapid traverse (X/Y/Z)	m/min	30/30/30, opt:40/40/40(FANUC)		30/30/30, opt:40/40/40(FANUC)		30/30/30, opt:40/40/40(FANUC)		20/30/30, opt:30/30/30		20/30/30, opt:24/20/20		20/20/20, opt:20/16/20	
Cutting feed rate	mm/mm	1-20000		1-20000		1-20000		1-15000		1-15000		1-15000	
<b>ATC &amp; MAGANIZE</b>													
ATC Type		Armless type	Armless type	Arm type	Armless type	Arm type	Armless type	Arm type	Arm type	Arm type	Arm type	Arm type	Arm type
Maganize capacity	pcs	16	12	30	16	30	20	30	24/opt:32/60/90	24/opt:32/60/90	24/opt:32/60/90	24/opt:32/60/90	24/opt:32/60/90
Max. tool dia.(next empty)	mm	40	75/125	75/150	75/125	75/150	75/125	75/150	130/250	130/250	130/250	130/250	130/250
Max. tool length	mm	150	250	250	250	300	250	300	350	350	350	350	350
Max. tool weight	kg	1.5	7	7	7	7	7	7	15	15	15	15	15
<b>SPACE &amp; SYSTEM REQUIREMENT</b>													
Pneumatic pressure	Kgf/cm	6	6	6	6	6	6	6	6	6	6	6	
Electrical power consumption	kVA	50	50	50	75	75	90	90	90	90	90	90	
Machine net weight(without opt.)	kg	6000	8500	14500	20000	23000	30000	35000	36000	42000	42000	49000	
Max. floor space(WxLxH)	mm	2900x2050x2800	3500x3500x3000	4000x3500x3200	5000x3600x3800	5500x3600x3800	6500x4100x4300	6500x4700x4300	8500x4100x4300	8500x4700x4300	10500x4100x4300	10500x4700x4300	

\* Specifications are subject to change without notice.

## ACCESSORIES

### STANDARD ACCESSORIES

- HEIDENHAIN TNC 620/ TFT15"LCD
- Ethernet USB, RS-232C interface
- Fully enclosed splash guard
- Spindle cooler
- 3 Axes absolute encoder motors
- ATC
- 3 Axes linear guide way
- X/Y/Z ; BOSCH Rexroth/P class /55 type/roller type or same class
- Cutting coolant system
- Centralized AUTO lubrication system
- Spindle air blast
- Working lamp
- Indication lamp
- Anchor bolts, leveling blocks and bolts
- Screw type conveyor x2(Table side)
- Tool kits
- Washing gun & air gun
- Coolant tank
- Cutting air blast
- Operation manual

### OPTIONAL

- Direct-drive / Built-in/type high speed spindle
- Heidenhain TNC640 controller  
FANUC 0i/31i controller  
MITSUBISHI M80/M830 controller  
SIEMENS 828D/840D controller  
FAGOR 8060/8065 controller
- Linear scale(3 axes)
- Arm / Armless type tool maganize
- Auto grease lubrication system
- Transformer & regulator
- Tool length measurement system
- Workpiece measurement system
- Oil mist cutting system
- Spindle thermal compensation system (for IBAG spindle only)
- Oil mist collector
- CTS
- Steel belt / Scraper type chip conveyor
- 4th axes
- Oil skimmer
- Column heighten
- DD motor
- Spindle gear box/gear head