

*F*antastic *P*erformance

Vcenter - F76 / F106 FX400

Vertical machining center

- Travels (X/Y/Z):
760 / 500 / 510 mm (F76)
1060 / 600 / 560 mm (F106)
600 / 500 / 500 mm (FX400)
- Rapid feeds 32/32/32 m/min
- 8000 rpm spindle output 15 kW (S3) (F76/F106)
12000 rpm spindle output 15 kW (30 min.) (FX400)
- Roller guideways and Ø40 mm ballscrews
- Screw chip removers included



Vcenter-F series: Your First VMC with Fantastic Performance

- Victor's own spindle (8000/10000 rpm)
- A-shaped column with long Y-axis travel
- Roller type guideways
- High rapid feeds 32 m/min

X/Y/Z AXES

Travels: 760 / 500 / 510 mm (F76)
1060 / 600 / 560 mm (F106)

Rapid feeds: 32/32/32 m/min

Ballscrew diameter: 40/40/40 mm

Guideways: 30/35/45 mm (F76)
35/40/45 mm (F106)

ATC

Capacity: 24 tools (opt. 30)

Tool exchange time:

2.4 sec. (tool-tool)

5.7 sec. (chip-chip)

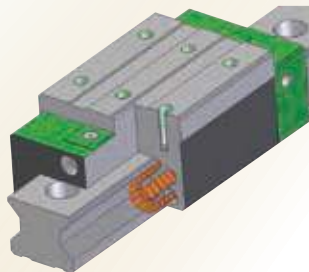

Roller guides

TABLE

Max. load: 500 kgs (F76)
600 kgs (F106)

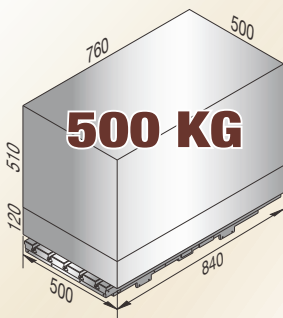

Vcenter-F76

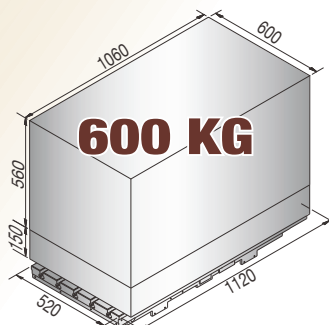

Vcenter-F106





SPINDLE

- Spindle output 15 kW
- BT-40 belt-driven 8000 rpm spindle
- NN type double roller bearings
- Victor Taichung's own spindle built in house
- Opt. with 10000 rpm spindle



Spindle Output Diagram

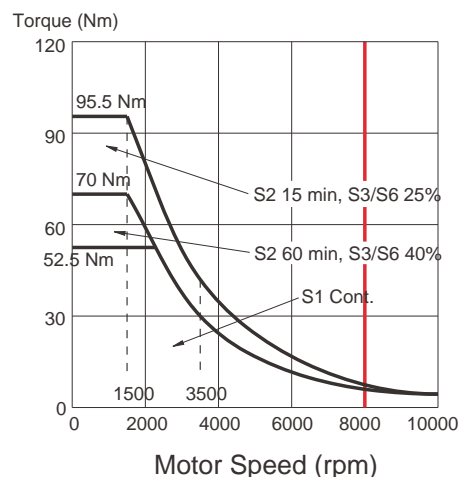
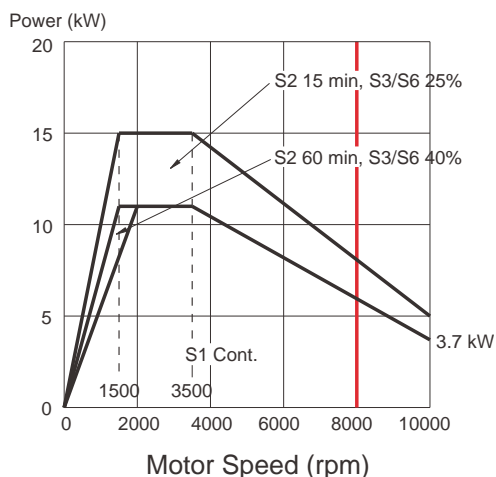

STRUCTURE

- Wide span column
- Certificated casting



Certificated Casting

GA350

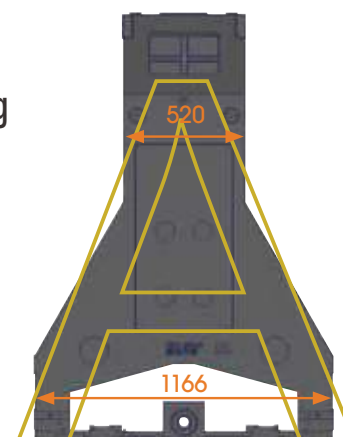

Column with wide span

1166 mm (F76)
1270 mm (F106)

Vcenter-FX400: Your First 5-axis Machine with Fantastic Performance

- Maximum part dimension: $\varnothing 400$ x H160 + $\varnothing 220$ x H250 mm
- Trunnion type tilting table $\varnothing 320$ mm
- Fanuc OiMF Plus control for 4+1 axis machining
- 12000 rpm BBT-40 spindle directly coupled to spindle motor

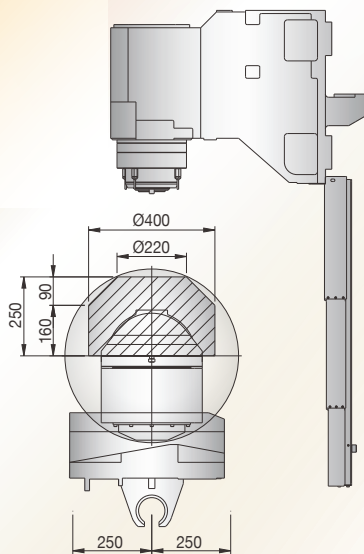
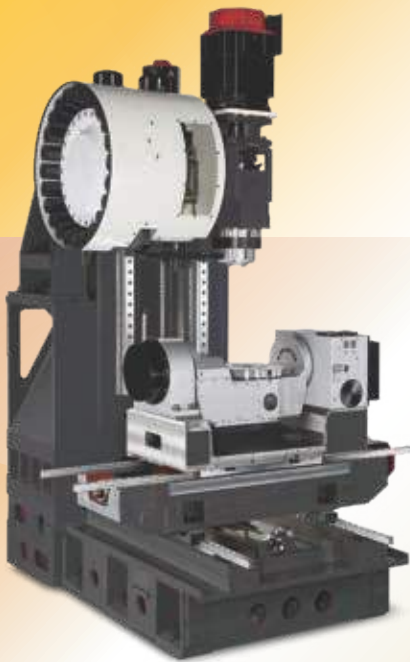

X/Y/Z AXES

Travels: **600/500/500 mm**
Rapid feeds: **32/32/32 m/min**
Ball screw diameter: **40/40/40 mm**
Guideways: **30/35/45 mm**

ATC

Capacity: **24 tools (opt. 30)**
Tool exchange time:
2.4 sec. (tool-tool)
5.7 sec. (chip-chip)

ROTARY TABLE

Dimension: **$\varnothing 320$ mm**

Table load: **200 kgs**

- Worm gear & shaft mechanism
- High wear resistance with copper alloy worm gear (patented CU80D) & fully lubricated worm shaft
- Dual-lead worm with minimal backlash





BigPlus[®] BBT-40 Spindle

18.5 kW* (S3-25%)

12000rpm

(* opt. 15 kW with CTS)



Fanuc α i12/12000 (std. without CTS)

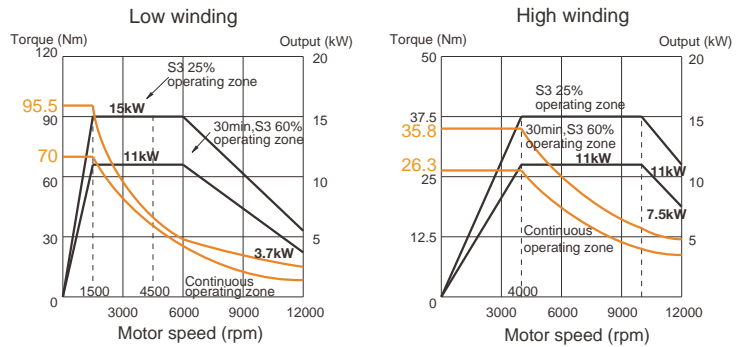

Fanuc α iT8/12000 (opt. with CTS)

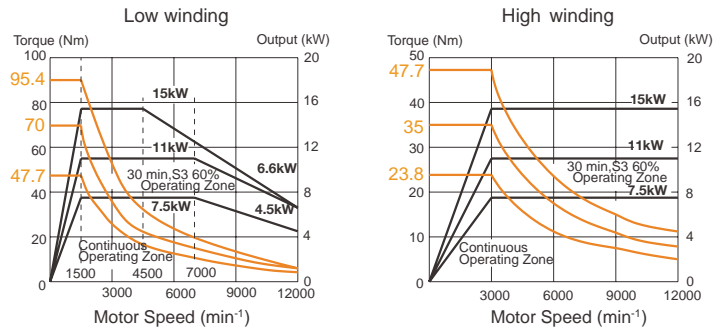

Chip & Coolant Disposal

- 2 screw chip removers
- High sloped angle bottom guarding



Vcenter-F series

Standard Accessories

Fanuc Oi-MF Plus (10.4") control with Manual Guide I (MGI)
+ AICC-2 (200 blocks) for user friendly operation

Victor Taichung's GUI "VSS macros"



Smart workpiece measurement



Adaptive cutting at constant loading



Tool management



Renishaw® GUI



Convenient maintenance



Arm type ATC + Coolant ring
+ LED lights



Bottom guarding flush
(Vc-F106) + Screw chip
removers

Optional Accessories



Spindle oil cooler
(std. for FX400)



CTS (Coolants Thru. Spindle)



Auto tool length
measurement



Auto part measuring



Linear scales



4th axis interface for
rotary table



Chip conveyor

Machine Specification

Item	Unit	Vcenter-FX400	Vcenter-F76	Vcenter-F106
Travel	X axis travel	mm	600	1060
	Y axis travel	mm	500	600
	Z axis travel	mm	500	560 (opt. 760)
	A/C axis travels	deg.	+30°~ -120°/ 360°	-
Distance	Spindle center to column	mm	547	627
	Spindle nose to table surface	mm	20 ~ 520	120 ~ 630 (opt. 810)
Table	Table work area	mm	Ø320	840 x 500
	Dimension of T-slot	mm	12H7	4 x 18 x 100
	Max. table load	kg	200	500
Spindle	Spindle taper		BBT-40	BT-40
	Spindle motor - cont./ 25% (15 min)	kW	11 / 15	11 / 15
	Spindle speed	rpm	12000	8000 (opt. 10000)
Feed rate	Rapid feed rate - X/Y/Z (Fanuc)	m/min	32 / 32 / 32	32 / 32 / 32
	Rotary rapid feed rate - A/C (Fanuc)	rpm	16 / 25	-
	Axis acceleration - X/Y/Z	m/sec ²	0.4G / 0.4G / 0.5G	0.5G / 0.5G / 0.5G
	Axis feed motor - X/Y/Z/A/C	kW	2.5 / 2.5 / 3 / 1.4 / 1.2	2.5 / 2.5 / 3
	Cutting feedrate by table	m/min	20	20
	Continuous torque output	N-m	1260 / 700 (A/C)	-
	Braked torque (clamping)	N-m	1500 / 750 (A/C)	-
	X/Y/Z ballscrew (dia. x pitch)	mm	40 x P16 (X/Y/Z)	40 x P16 (X/Y/Z)
Linear guide width (X/Y/Z)	mm	30 / 35 / 45	30 / 35 / 45	
Tools	Max. tool length	mm	300	300
	Max. tool weight	kg	7	7
	Magazine capacity		24 (opt. 30)	24 (opt. 30)
	Max. tool diameter (without adjacent tools)	mm	75 (150)	75 (150)
	Tool exchange time	sec.	2.4 (T-T), 5.7 (C-C)	2.4 (T-T), 5.7 (C-C)
	Pull stud angle	deg.	15 (JIS 40P)	15 (JIS 40P)
	Tool selection method		Random	Random
Accuracy (ISO 230-2)	Positioning accuracy (bi-directional)	mm	0.010 (X/Y/Z) 0.0056° (A/C)	0.010
	Repeatability	mm	0.007 (±0.0035) 0.003° (A/C)	0.007 (±0.0035)
Machine	Power requirement	KVA	27 (excl. CTS)	22 (excl. CTS)
	Min/Max. air pressure	kg/cm ²	5.5 ~ 6.5	5.5 ~ 6.5
	Coolant tank capacity	L.	220	220
	Std. NC controller (Fanuc)		Oi-MF Plus (10.4", type-1)	Oi-MF Plus (10.4", type-3)
	Floor space requirement	mm	2720 x 2730	2714 x 2782
	Max. machine height	mm	2962	2578
	Machine weight	kg	6100	5260

Standard Accessories:

- Fully enclosed splash guard
- Fanuc Oi-MF Plus (10.4") control
- Screw-type chip remover (left disposal)
- Air blow (manual control)
- Rigid tapping
- Remote MPG
- Hand tools and toolbox
- T nuts for table slot
- 3-step warning light
- Leveling pads

Optional Accessories:

- Spindle oil cooler (std. for FX400)
- Air conditioner for electric cabinet
- Air blow (controlled by M-code)
- Auto power off
- Chip conveyor with cart
- Coolant through spindle (CTS)
- 10000 rpm spindle (excl. Vc-FX400)
- 30 tool magazine
- Auto tool length measurement
- Auto part measuring
- Stop block for special tools
- 4th/5th axis interface
- Auto door
- Oil skimmer
- Linear scales
- Air gun
- Coolant gun
- Rotary tables
- Fanuc OiMF Plus (10.4", type-1) control (Vc-F76/F106)
- Fanuc OiMF Plus (15", type-0) control
- Siemens control 840D SL (full 5-axis control)

Victor Taichung's FANUC Oi-MF Plus (10.4") Control Specification



Standard

ITEM	SPECIFICATION	DESCRIPTION
Operation & Program Input:		
1.	Input / Output interface	RS-232, PCMCIA Card, USB
2.	Tool Offset Pairs	± 6-digit, 400
3.	Program Number	O4-Digit
4.	Sequence Number	N5-Digit
5.	M Code Function	M3 digit
6.	S Code Function	S5 digit
7.	T Code Function	T2 digit
8.	Program Display	Program name 31 characters
9.	Positioning	G00
10.	Linear Interpolation	G01
11.	Circular Interpolation	G02, G03
12.	Helical interpolation	Std.
13.	Skip Function	G31
14.	Reference Position Return	G28, G30
15.	Absolute / Incremental Programming	G90 / G91
16.	Plane Selection	G17, G18, G19
17.	Polar coordinate Command	G16
18.	Workpiece Coordinate System	6+48 sets (G54~G59, G54.1)
19.	Addition of Workpiece Coordinate System Pair	48 Pairs
20.	Optional Chamfering/Corner R	Std.
21.	Sub Program Call	4 folds nested
22.	Custom macro B	Std.
23.	Addition of Custom Macro Common Variables	#100~#199, #500~#999
24.	Canned cycle For Drilling	G73 / G74 / G76, G80-G89
25.	Small hole peck drilling cycle	G83
26.	Program Stop / Program End	M00 / M01 / M02 / M30
27.	Scaling	G51
28.	Rigid tapping	M29
29.	Coordinate System Rotation	G68
30.	Programmable mirror image	G50.1
31.	Manual Guide I (MGI) conversational programming	Std.
32.	Fine Surface Machining	Std.
33.	Smooth tolerance control+	Std.
Controlled Axes:		
1.	Controlled Axes	3 Axes (X, Y, Z)
2.	Simultaneous Controlled Axes	4 Axes
3.	Least Input Increment	0.001 mm
4.	Least command increment	0.0001 mm
5.	HRV Control	HRV3+
6.	Unexpected disturbance torque detection (AIR-BAG)	Std.
7.	Backlash compensation	Std.
8.	Stored pitch error compensation	Std.
Feed:		
1.	Rapid Traverse Override	F0, 25%, 50%, 100%
2.	Feed Per Minute	G94 (mm/min)
3.	Feed rate Override	0~150% (0~200% for Vc-FX400)



4.	Spindle Override	50~120% (60~200% for Vc-FX400)
5.	Manual Handle Feed Rate	X1, X10, X100
6.	AI contour control (AICC, G05.1) (in total)	200 blocks
Edit Operation:		
1.	Part Program Storage Length (in total)	5120m
2.	Part Program Editing / Protect	Std.
3.	Memory Card Editing (Max. 63 programs.)	Std.

OPTIONS

ITEM	SPECIFICATION	DESCRIPTION
With hardware included:		
1.	Data server (with PCB and CF card 1GB)	<input type="checkbox"/>
2.	Ethernet/IP (to be linked to robot)	<input type="checkbox"/>
3.	Profinet (to be linked to robot)	<input type="checkbox"/>
4.	CC-Link (to be linked to robot)	<input type="checkbox"/>
5.	Fast Ethernet (required for SCADA Web with additional RJ45 port)	<input type="checkbox"/>
6.	15" LCD (type-0 control) - avail. on Vc-FX400	<input type="checkbox"/>
Without hardware included:		
7.	Tool load monitoring (with Victor own PLC)	<input type="checkbox"/>
8.	Cylindrical interpolation (G7.1) (used on 4th axis) (std. for Vc-FX400)	<input type="checkbox"/>
9.	Addition of work-piece coordinate systems 300 sets	<input type="checkbox"/>
10.	Tilted working plane indexing command (std. for Vc-FX400)	<input type="checkbox"/>
11.	Memory card program entry count extension (Max. 1000)	<input type="checkbox"/>
12.	AI contour control (G05.1, 400 blocks) - avail. on type-0 control	<input type="checkbox"/>
13.	Smooth TCP (Tool Center Point) - avail. on Vc-FX400 with type-0 control	<input type="checkbox"/>

Tool Shank

BT-40

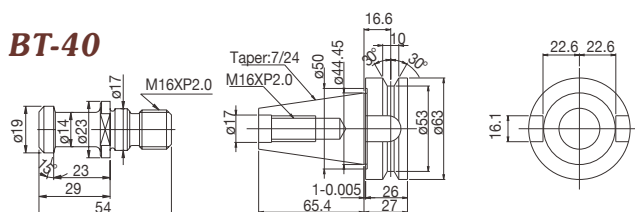

SK-40

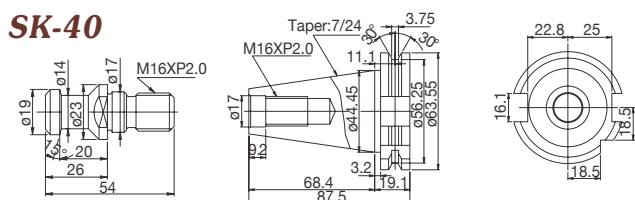

Machine Color Option



Standard



RAL-7024

Machine Layout

Vcenter-F76

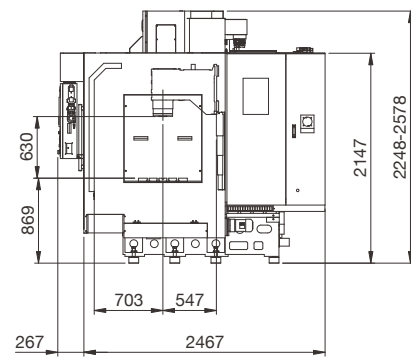
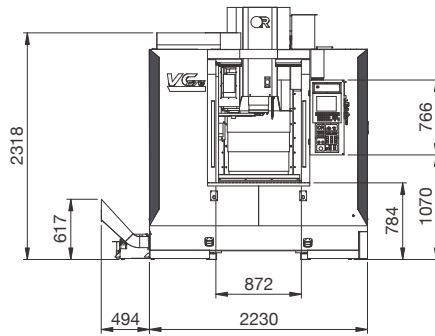
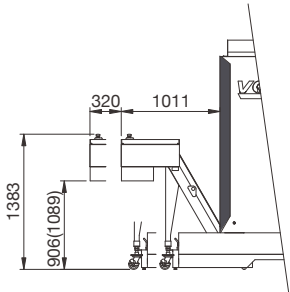
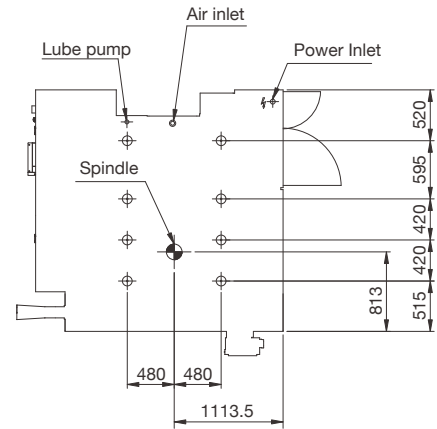
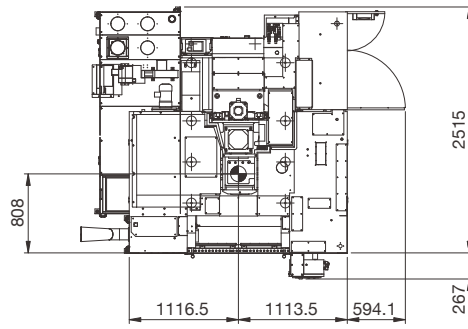
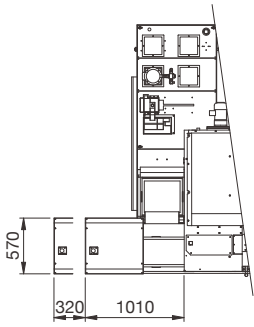

chip conveyor

Unit: mm

Vcenter-F106

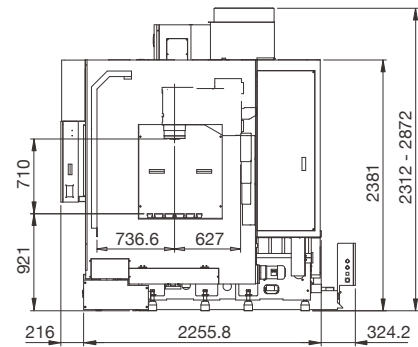
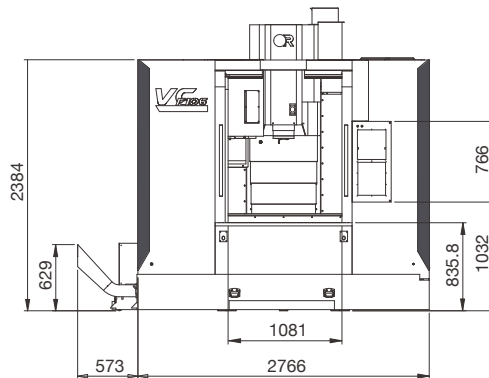
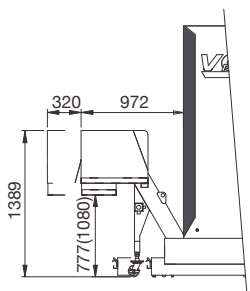
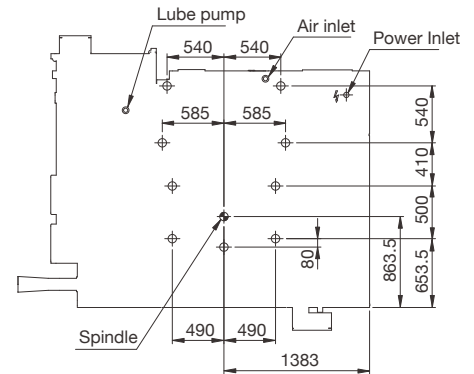
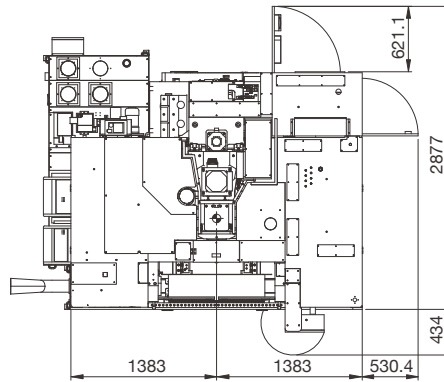
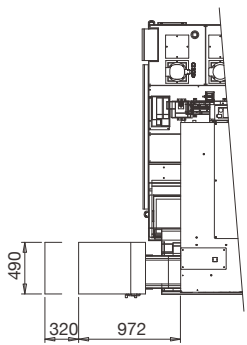

chip conveyor

Unit: mm

Machine Layout



Vcenter-FX400

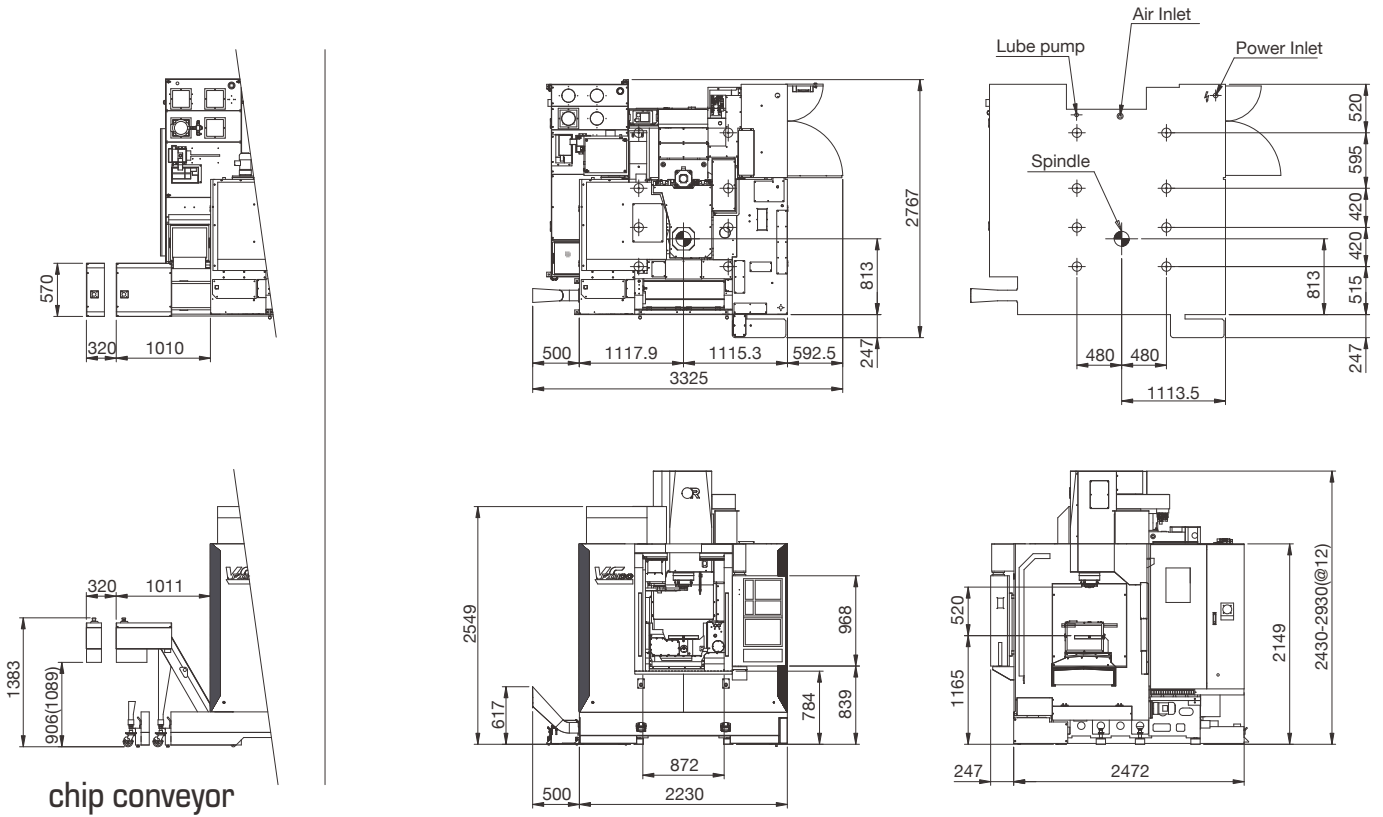

Unit: mm

Table Spec & Machining Range

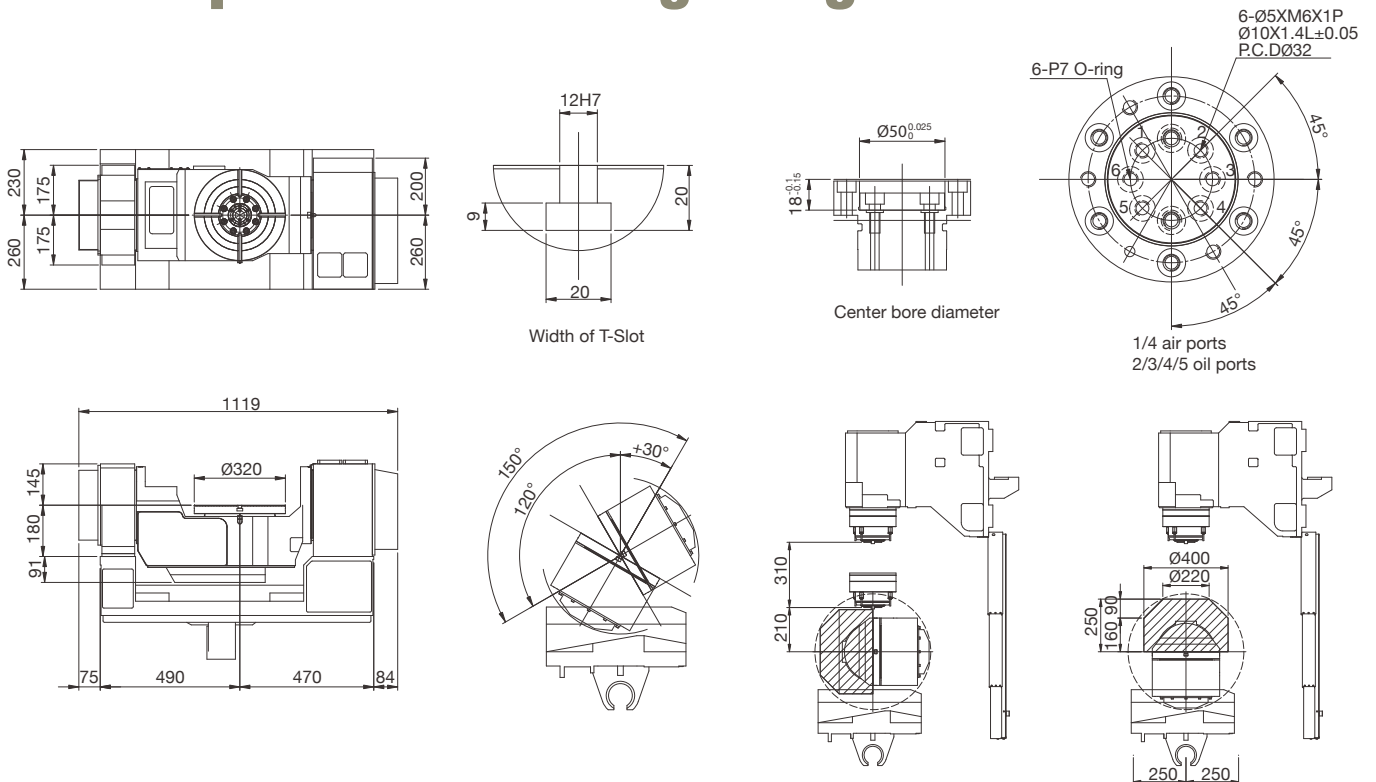



ONWARD RISE

To ensure the return on investment, Victor Taichung has invested considerably in setting up a distribution network in terms of global vision local touch for our sales and service supports worldwide. Besides the qualified exclusive agents around the world, Victor Taichung has 7 overseas subsidiaries to provide our customers efficient after-sales service and technical supports.

 **VICTOR TAICHUNG** profile:
 Sales turnover: USD 207 mil's (in 2021)*
 No. of employees: 778
 *Exchange rate: 1 USD=28 TWD.



THE VICTOR-TAICHUNG COMPANIES

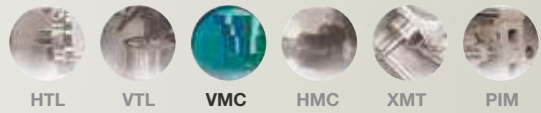

TAIWAN

<http://www.victortaichung.com>
 E-mail: info@mail.or.com.tw
 Victor Taichung Machinery Works Co., Ltd.
 No. 1, Jingke Central 2nd Rd.,
 Nantun Dist., Taichung 40852,
 TAIWAN, R.O.C.
 TEL : 886-4-23592101
 FAX : 886-4-23593389

FRANCE

Victor France
 TEL : 33-1-64772000
 FAX : 33-1-64772063

GERMANY

Victor GmbH
 TEL : 49-2261-478434
 FAX : 49-2261-478327

SOUTH AFRICA

Victor Fortune (PTY) Ltd.
 TEL : 27-11-3923800
 FAX : 27-11-3923899

MALAYSIA

Victor Machinery (M) SDN. BHD.
 TEL : 60-3-56337180
 FAX : 60-3-56337191

THAILAND

Victor (Thailand) Co. Ltd.
 TEL : 66-2-9263735
 FAX : 66-2-9032373

INDONESIA

PT. Victor Machinery Indonesia
 TEL : +62-21-88958504
 FAX : +62-21-88958513

USA

Fortune International Inc.
 TEL : 1-732-2140700
 FAX : 1-732-2140701

CHINA

Victor Taichung Machinery (Shanghai)
 TEL : 86-21-59768018
 FAX : 86-21-59768009