

Art of Smooth Performance

VTURN

S20/S26/S36

Strong
and
Steady
Turning
Center

- **Servo turret** (S20(CM), S26(CM), S36CM)
- **One-piece slant bed**
- **Box slideways**
- **High thrust force**
- **C-axis available**
- **Rotary operation panel**



Smooth & Steady Performance



Vturn-S20 Turning center

- One piece 30° slant bed
- Large swing diameter 600 mm
- 8" Power chuck / 4200 rpm
- Z-axis travel 400 / 600 mm (S20/40, S20/60)
- Machine width 2300mm only for Vturn-S20/40 with rear disposal chip conveyor
- High rapid feed 20/24 m/min (X/Z)
- Machine weight 4800 kg
- C-axis available



Spindle 12kW (S3-15%)

- Spindle output 246 Nm (S3-15%)
- Low base speed 349 rpm only
- NN type (roller type) bearings
- Shortened belt length
- Victor Taichung's own spindle

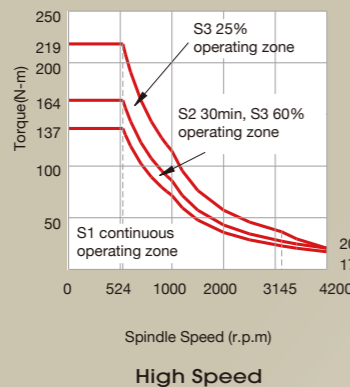
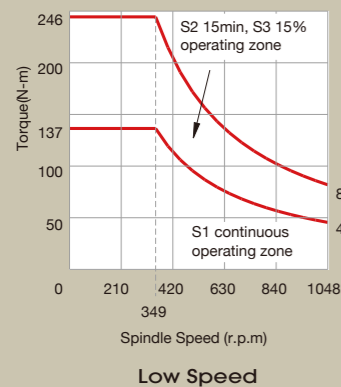
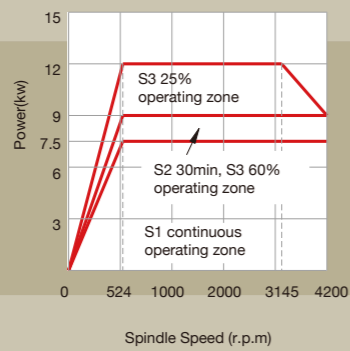
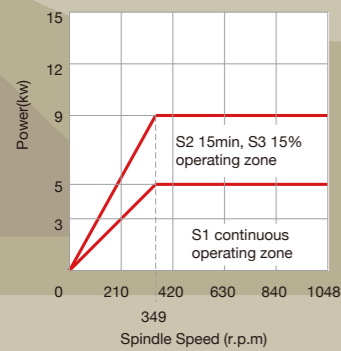

Boxways 55/70 mm (X/Z)

- High rapid feeds 20/24 m/min
- Smooth operation guaranteed
- Victor Taichung's own casting

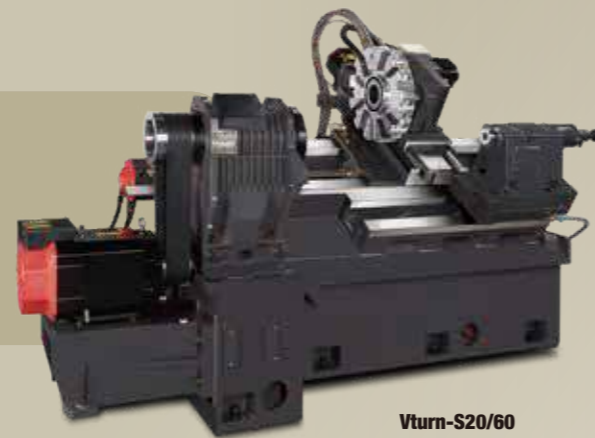

Vturn-S20/60

Tailstock MT-4

- Twin cylinder clamping
- Tow along by turret
- Opt. MT-3 with built-in bearings

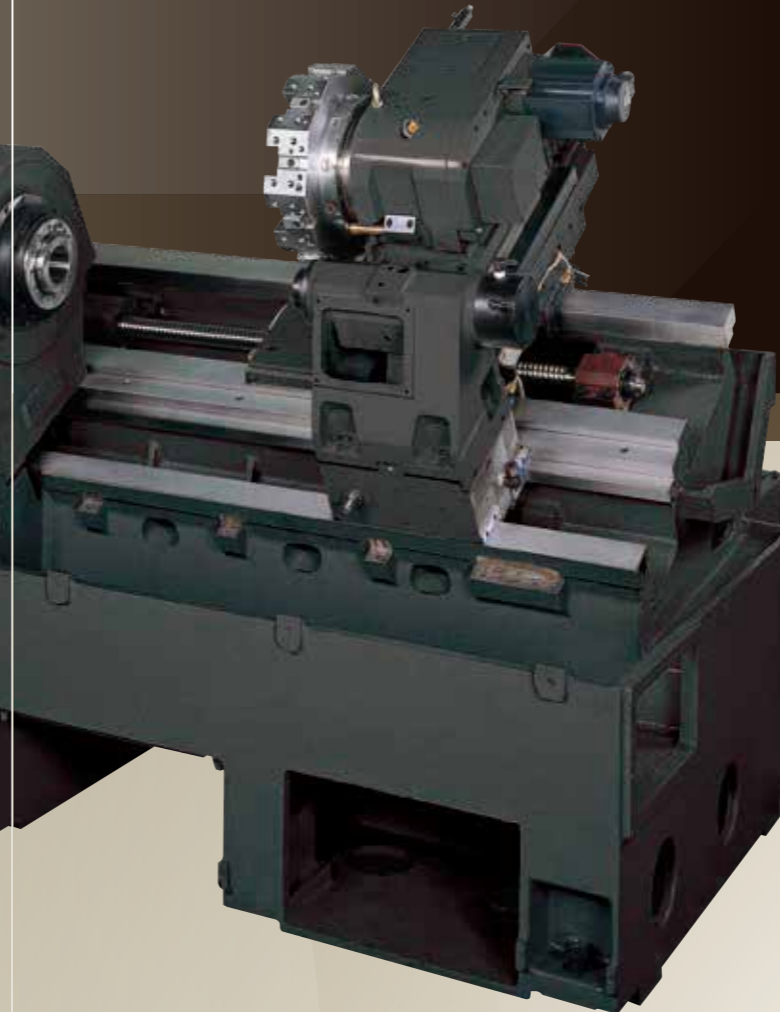

Vturn-S20/40



Servo Turret 0.8 sec. (adjacent tools)

- Turret indexing time 0.8 sec (adj.), 1.0 (opposite)
- High thrust (Z-axis) 852 kgf (8.36 kN)
- Milling turret BMT-55 (3-piece coupling)
- 12 station live tools
- Milling power 2.2kW/4000rpm (opt. 6000rpm)
- Victor Taichung's own turret

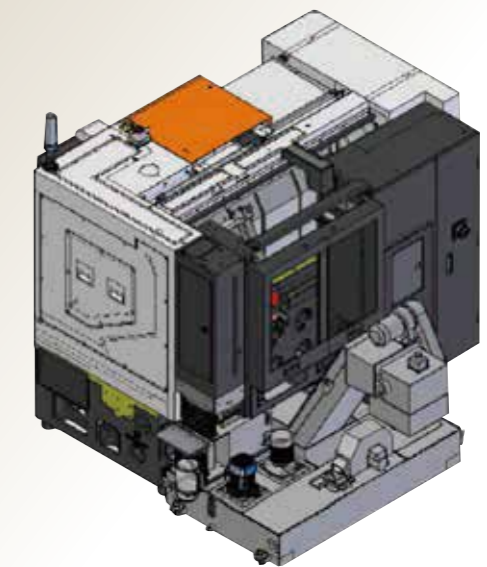

Rear / Right Chip Disposal

- Rectangular structure facilitates rear chip disposal (Vturn-S20/40 only) for less floor space (machine width 2300mm)
- Gantry robot can be mounted on machine base for high reliability and productivity

Smooth & Steady Performance



Vturn-S26 Turning center

- One piece 30° slant bed
- Large swing diameter 600 mm
- 10" Power chuck / 3500 rpm
- Z-axis travel 610 / 1100 mm (S26/60, S26/110)
- High thrust force 1582 kgf
- High rapid feed 18/24 m/min (X/Z)
- Machine weight 5750 / 6350 kg (S26/60, S26/110)
- C-axis available

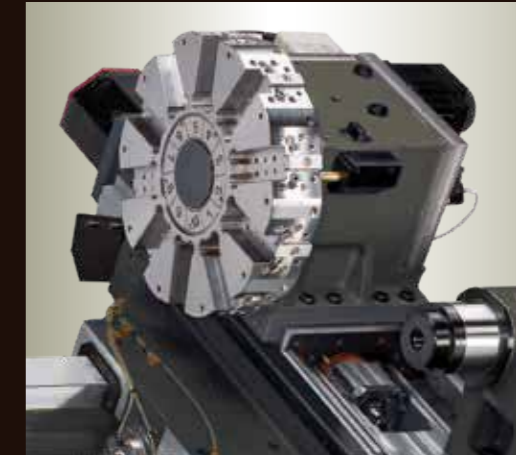
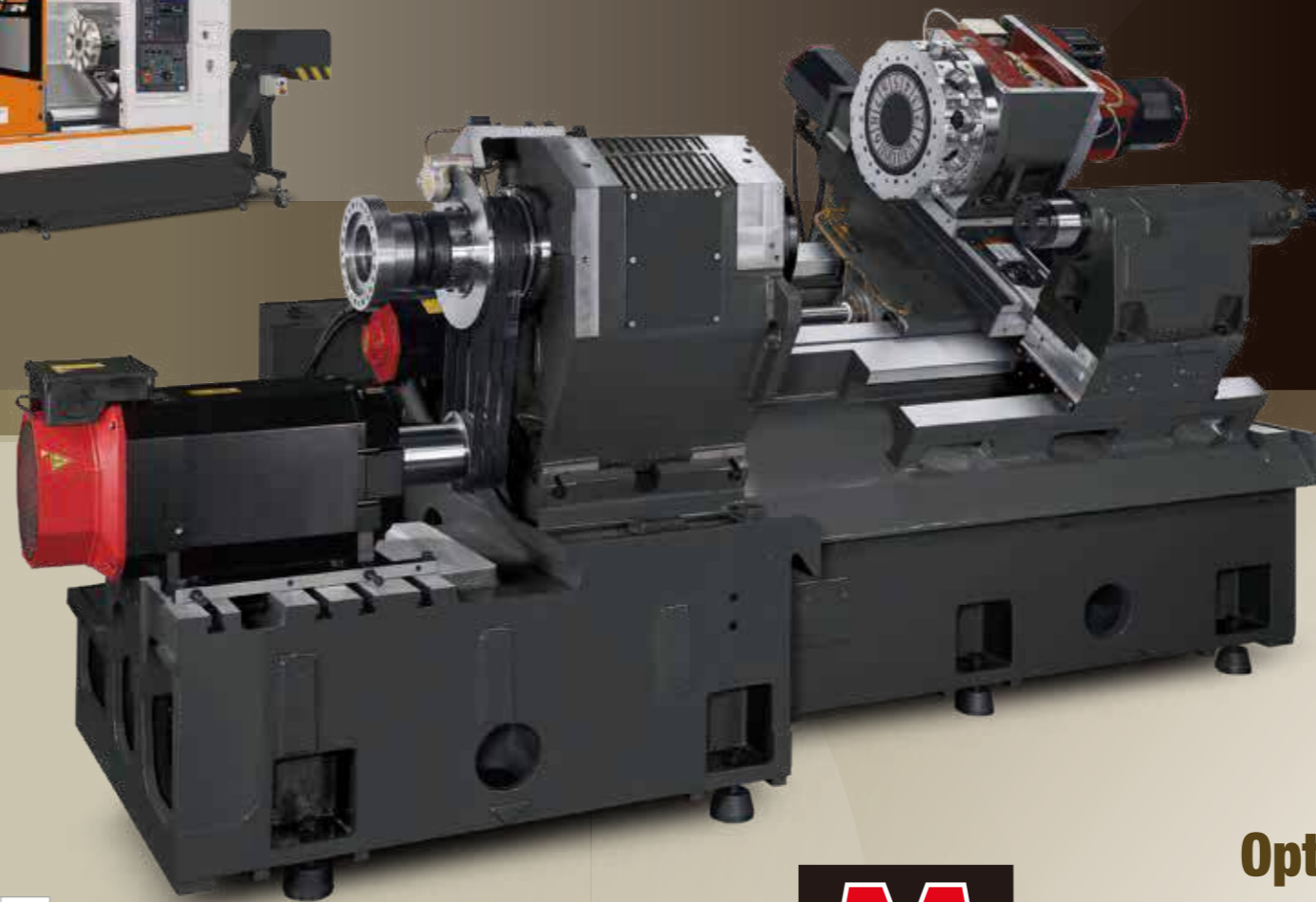

Servo Turret 0.8 sec. (adjacent tools)

- Victor Taichung's own turret
- Turret indexing time 0.8 sec (adj.), 1.0 (opposite)
- High thrust (Z-axis) 1441 kgf (14.1 kN)
- Milling turret BMT-65 (3-piece coupling)
- 12 station live tools
- Milling power 4.5kW/4000rpm (opt. 6000rpm)

Spindle 22kW (S3-25%)

- Spindle output 574 Nm (S3-25%)
- Low base speed 307 rpm only
- NN type (roller type) bearings
- Shortened belt length
- Victor Taichung's own spindle

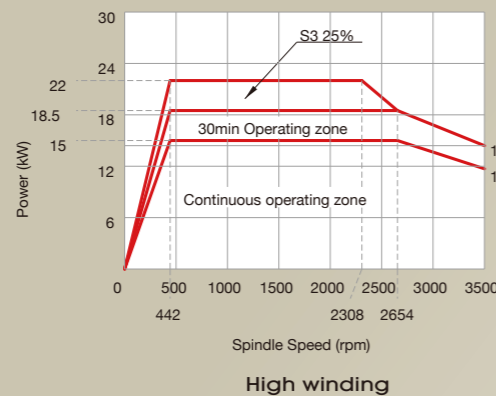
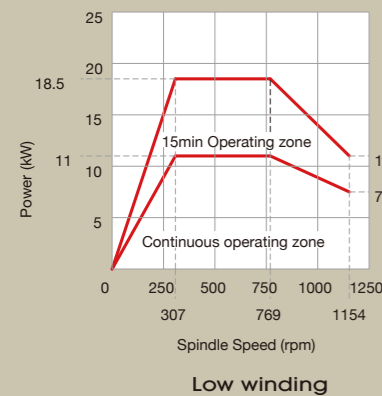
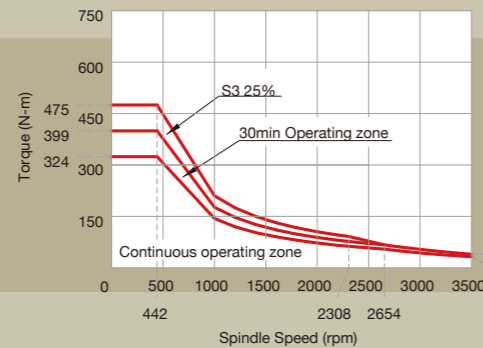
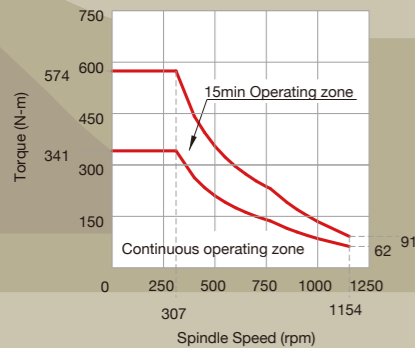

Conventional design
with much longer belts



Certificated Casting
GA350

Tailstock MT-5

- Twin cylinder clamping
- Tow along by turret
- Opt. MT-4 with built-in bearings

Boxways 64/80 mm (X/Z)

- High rapid feeds 18/24 m/min
- Smooth operation guaranteed
- Victor Taichung's own casting

Opt. Spindle 26kW (S3-25%)

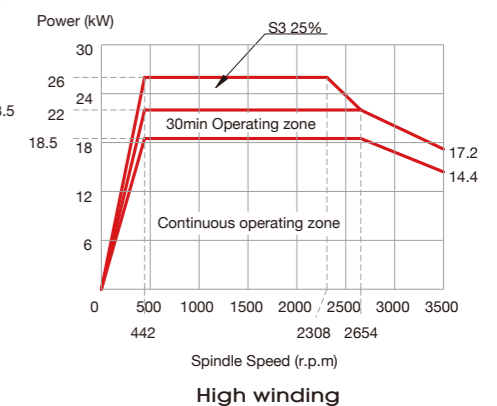
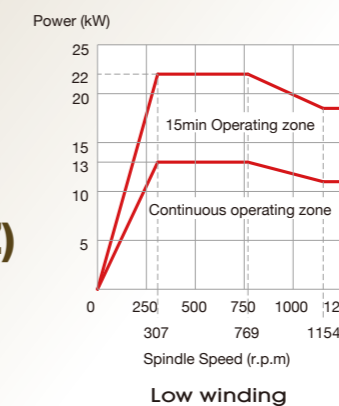
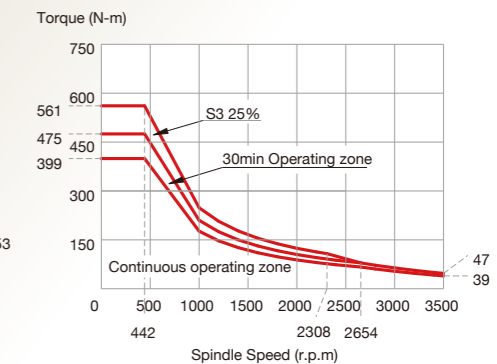
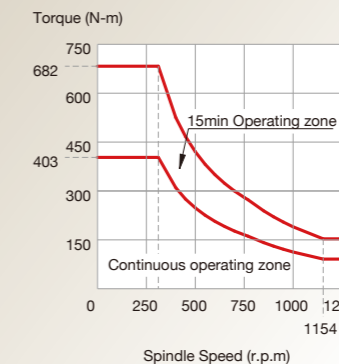

Strong Performance by 2-step Gearbox



Vturn-S36 Turning center

- A2-11 spindle with 2-step gearbox
- One piece 45° slant bed
- Large swing diameter 780 mm
- 12" Power chuck / 2500 rpm
- Z-axis travel 850 / 1250 mm (S36/85, S36/125)
- High thrust force 1582 kgf
- High rapid feed 18/20 m/min (X/Z)
- C-axis available with higher power spindle motor

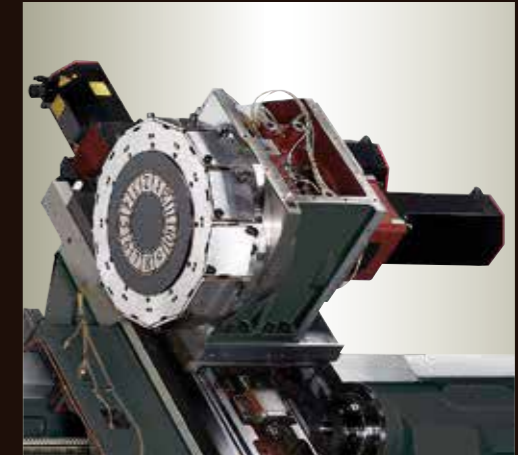
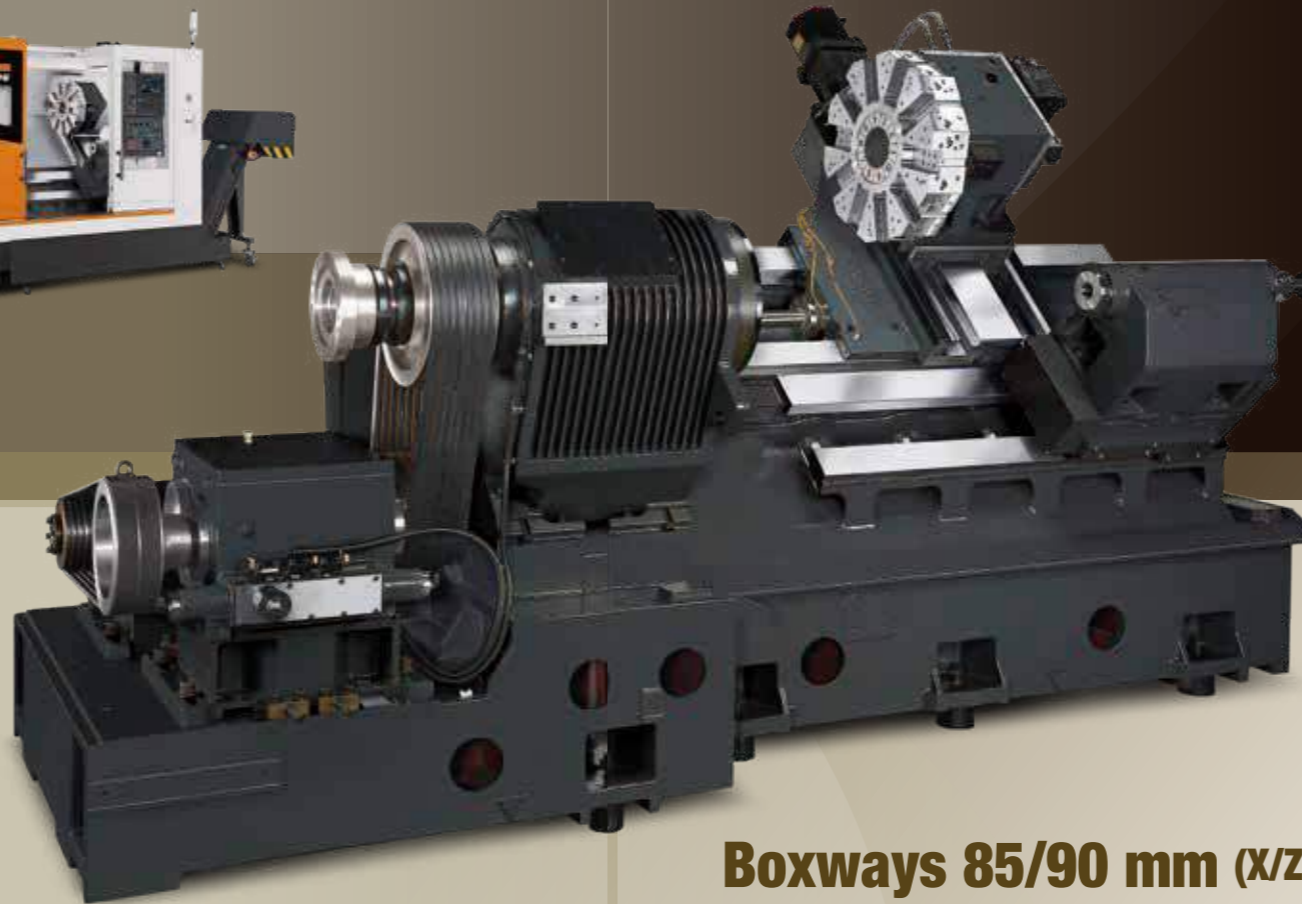

2-step gearbox

Victor's Own Turret

- Turret indexing time 0.9 sec. (adj.), 1.8 sec. (opposite)
- High thrust (Z-axis) 1582 kgf (15.5 kN)
- Opt. milling turret BMT-75 (3-piece coupling)
- 12 station live tools
- Milling power 7 kW / 3000 rpm

Boxways 85/90 mm (X/Z)

- High rapid feeds 18/20 m/min
- Smooth operation guaranteed

Tailstock MT-5

- Twin cylinder clamping
- Tow along by turret
- Opt. MT-4 with built-in bearings

Spindle 26kW (S3-25%)

- Spindle nose A2-11 with 2-step gearbox
- Spindle output 1201 Nm (S3-15%)
- Low base speed 278 rpm only
- NN type (roller type) bearings

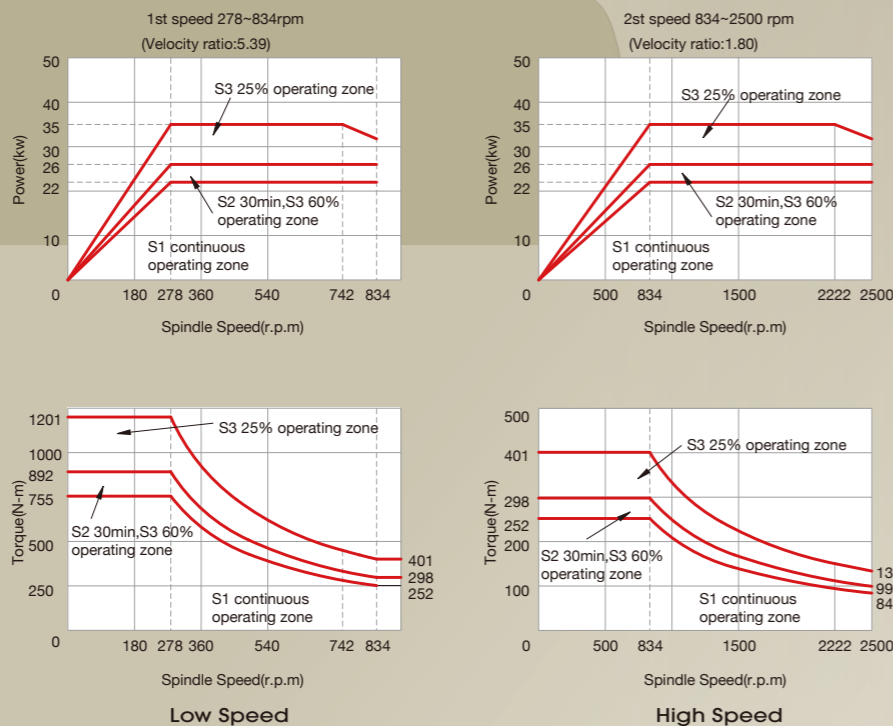

Cs-axis (opt.) with GTP[®] gearbox and upgraded spindle motor 45 kW (S3-25%)

- GTP[®] 2-step gearbox
- Spindle output 2010 Nm (S3-15%)
- Low base speed 214 rpm only

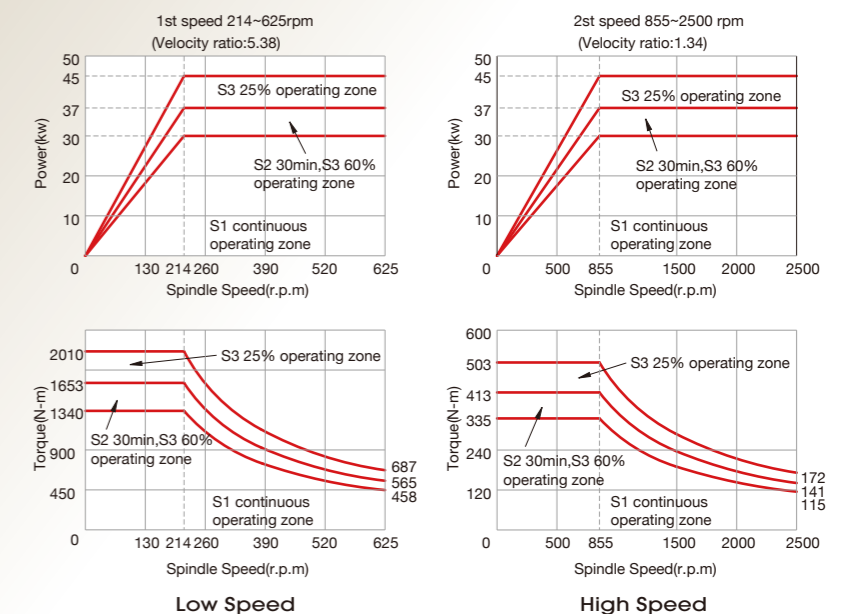

Standard and Options



- Fanuc Oi-TF Plus (type-1) control with 10.4" screen
- Programmable tailstock
- Rotary operation panel
- Door moving along LM guideways
- Coolant flush onto Z-axis covers
- Built-in LED light
- Pressure gauge in front
- Chip conveyor



Conveyor motor cover (opt.)



Transformer, A/C for cabinet (opt.)



15" screen (opt.)

Chip conveyor (std.)



Coolant flush (std.)



Tool presetter (opt.)



Gantry robot (opt.)



Tooling accessories (excl. BMT turret model)

TOOLS \ MODEL	Vturn-S20	Vturn-S26	Vturn-S36
Tool shank for turret disk	25 mm (1")	25 mm (1")	32 mm (1 1/4")
Maximum boring bar dia.	40 mm (1 1/2")	50 mm (2")	50 mm (2")
Face + OD cutting tool holder	1	1	1
Face + ID. cutting tool holder	1	1	1
Boring bar holder			
40 mm (1 1/2")	6	7	-
50 mm (2")	Opt.	1	5
Boring bar sleeve			
8 mm (5/16")	1	1	-
10 mm (3/8")	2	2	1
12 mm (1/2")	2	2	1
16mm (5/6")	2	2	2
20 mm (3/4")	2	2	2
25 mm (1")	2	2	2
32 mm (1 1/4")	2	2	2
40 mm (1 1/2")	-	-	2
Drill socket			
MT1	1	Opt.	-
MT2	1	1	-
MT3	1	1	Opt.
MT4	Opt.	1	1
U drill socket			
20 mm	Opt.	Opt.	-
25 mm (1")	1	1	1
32 mm (1 1/4")	1	1	1
40 mm (1 1/2")	-	-	Opt.

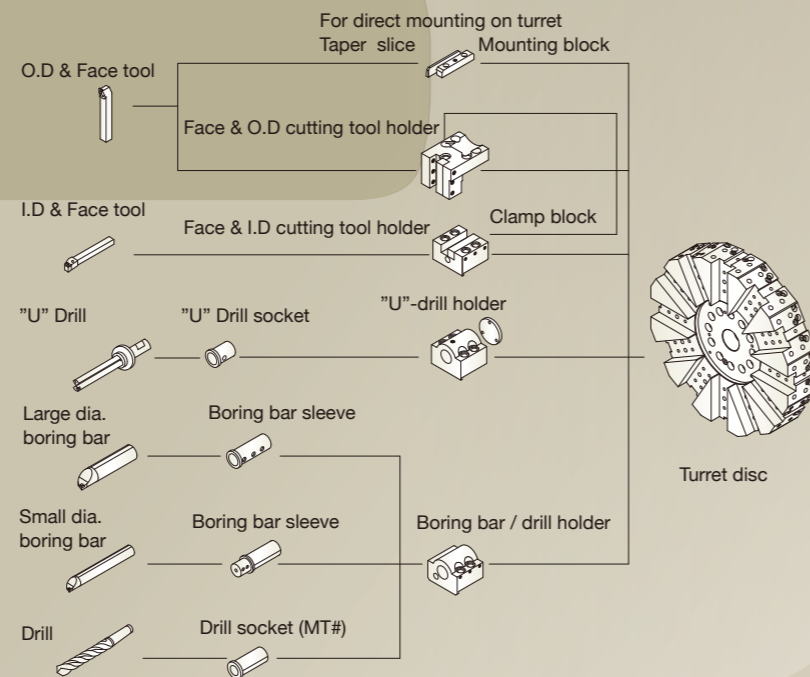

Recessed guarding for long tools (opt.)



Part catcher (opt.)



Oil skimmer (opt.)



Machine Color Option



Standard



RAL-7024

C-axis Application

(Bolt Mounted Milling Turret)

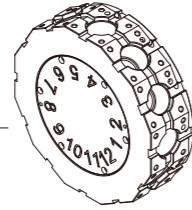
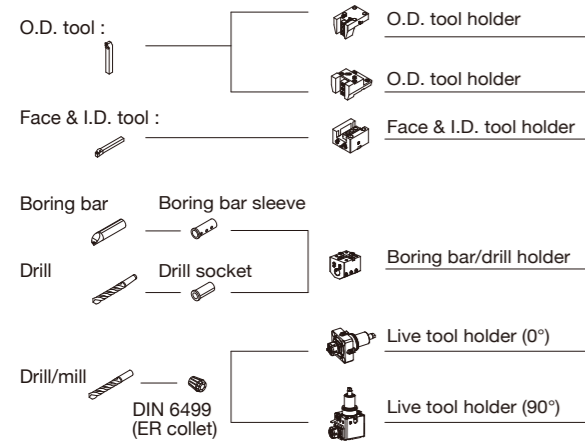

BMT-65 (Vturn-S26CM)

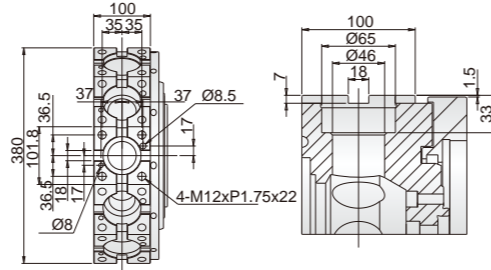

Vturn-S26

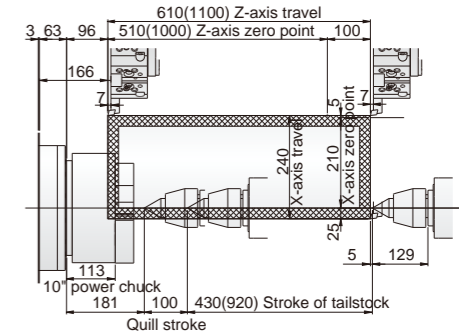
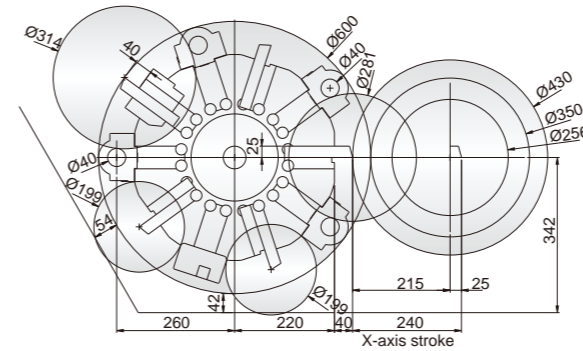

BMT-55 (Vturn-S20CM)

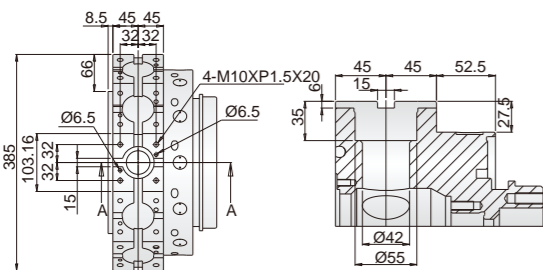

BMT-75 (Vturn-S36CM)

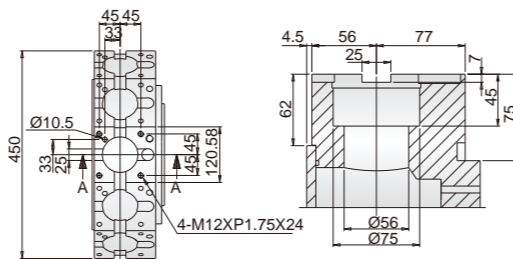

Vturn-S26CM

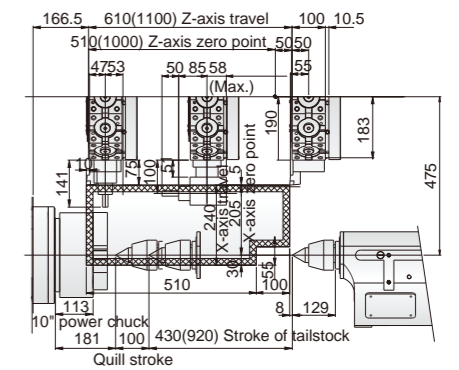
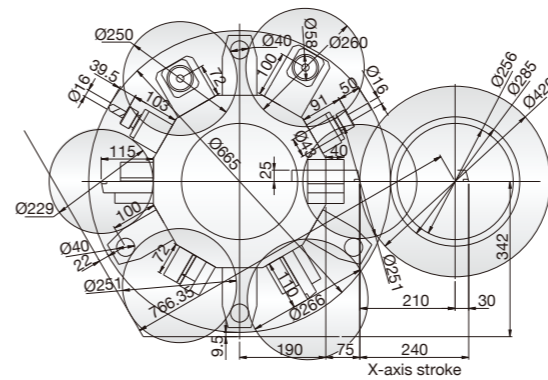

Interference Chart/Operating Range

Vturn-S20

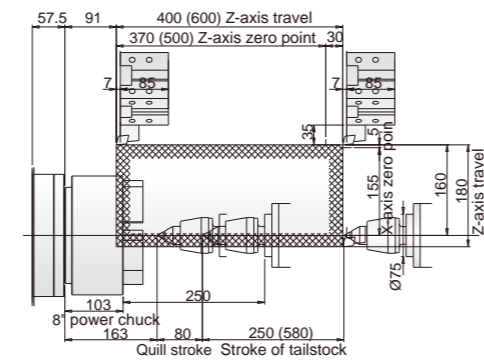
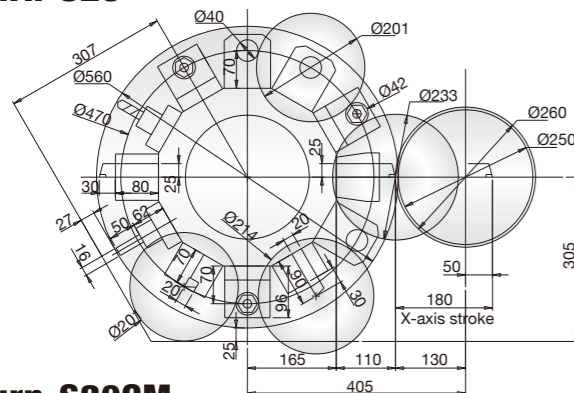

Vturn-S36

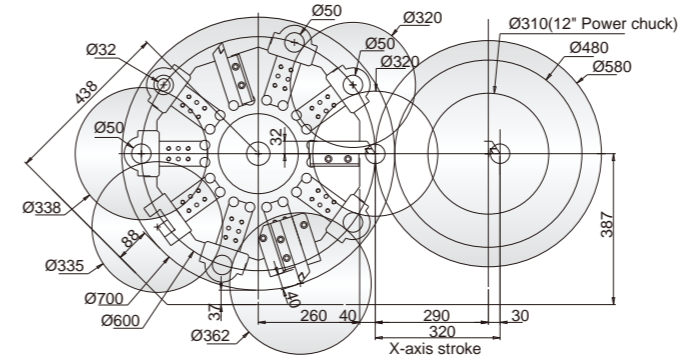

Vturn-S26/60 (S26/110)

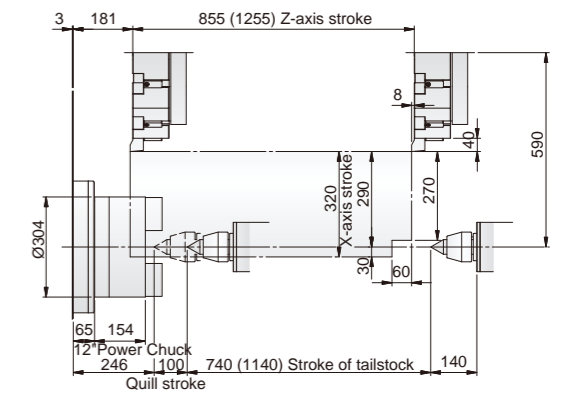

Vturn-S20CM

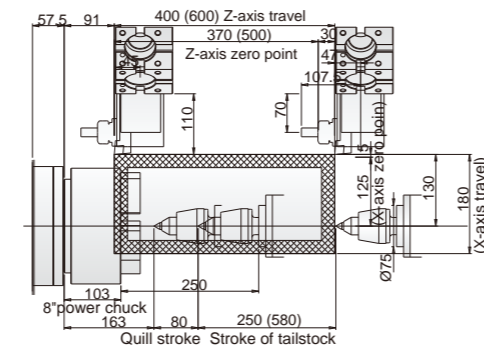
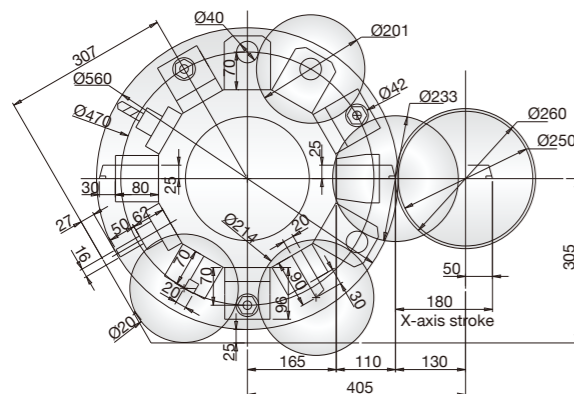

Vturn-S36CM

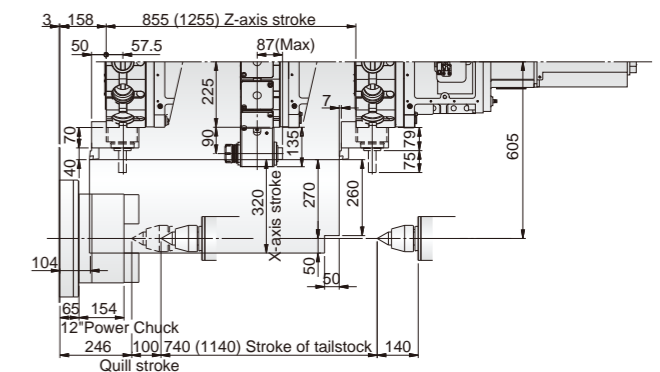
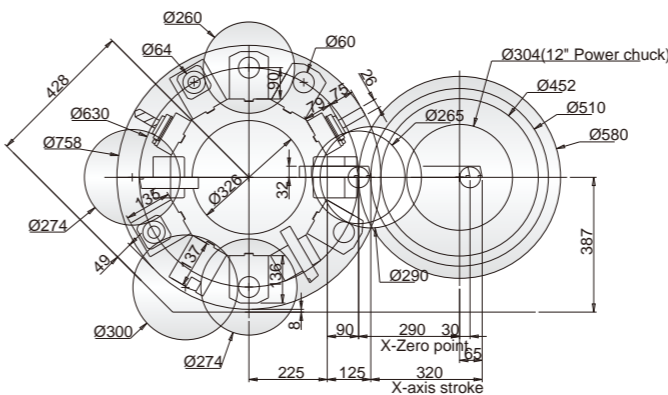

Vturn-S20/40 (S20/60)

Vturn-S36/85 (S36/125)

Machine Layout

Vturn-S20/40 (std. rear disposal chip conveyor)

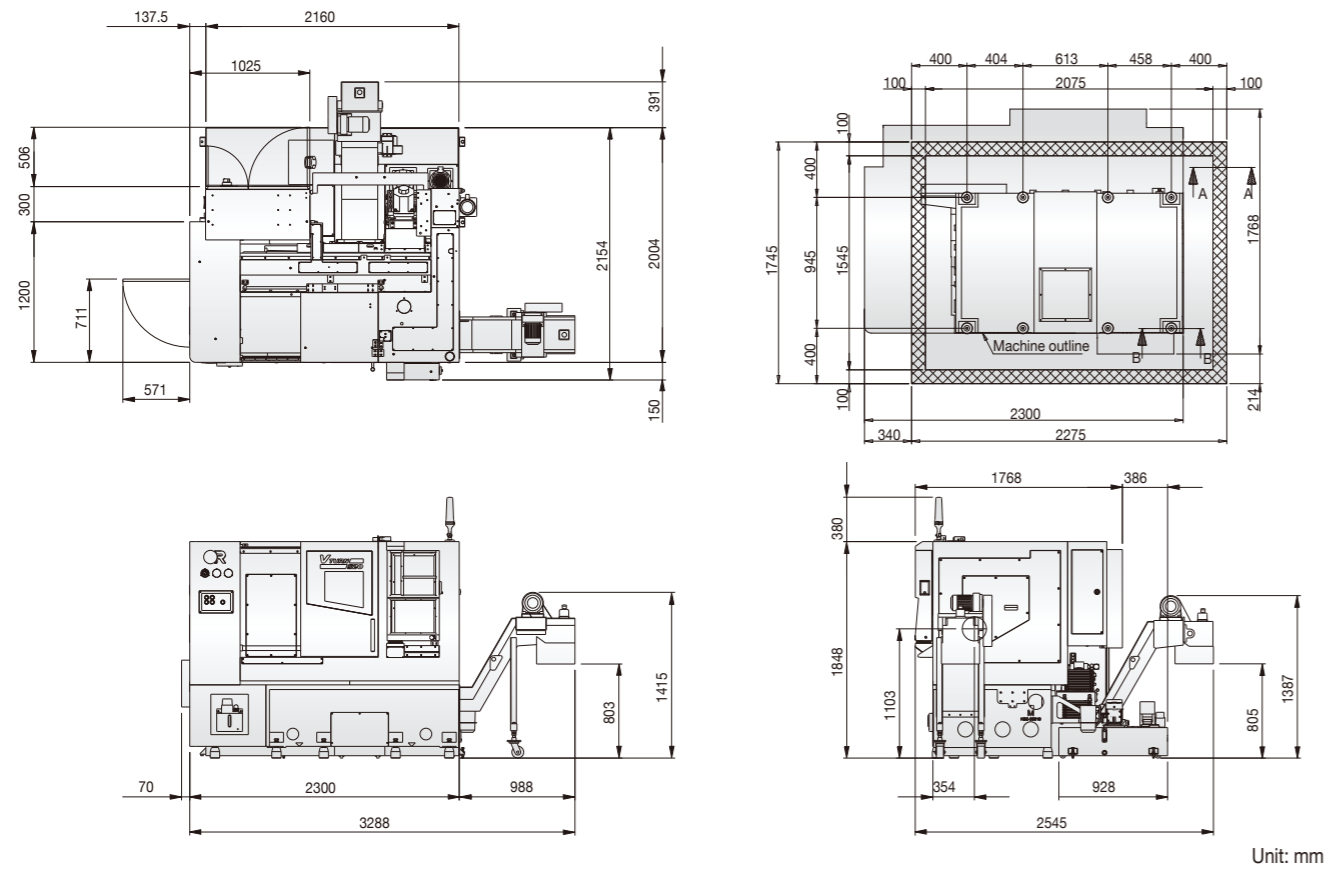

Vturn-S20/60

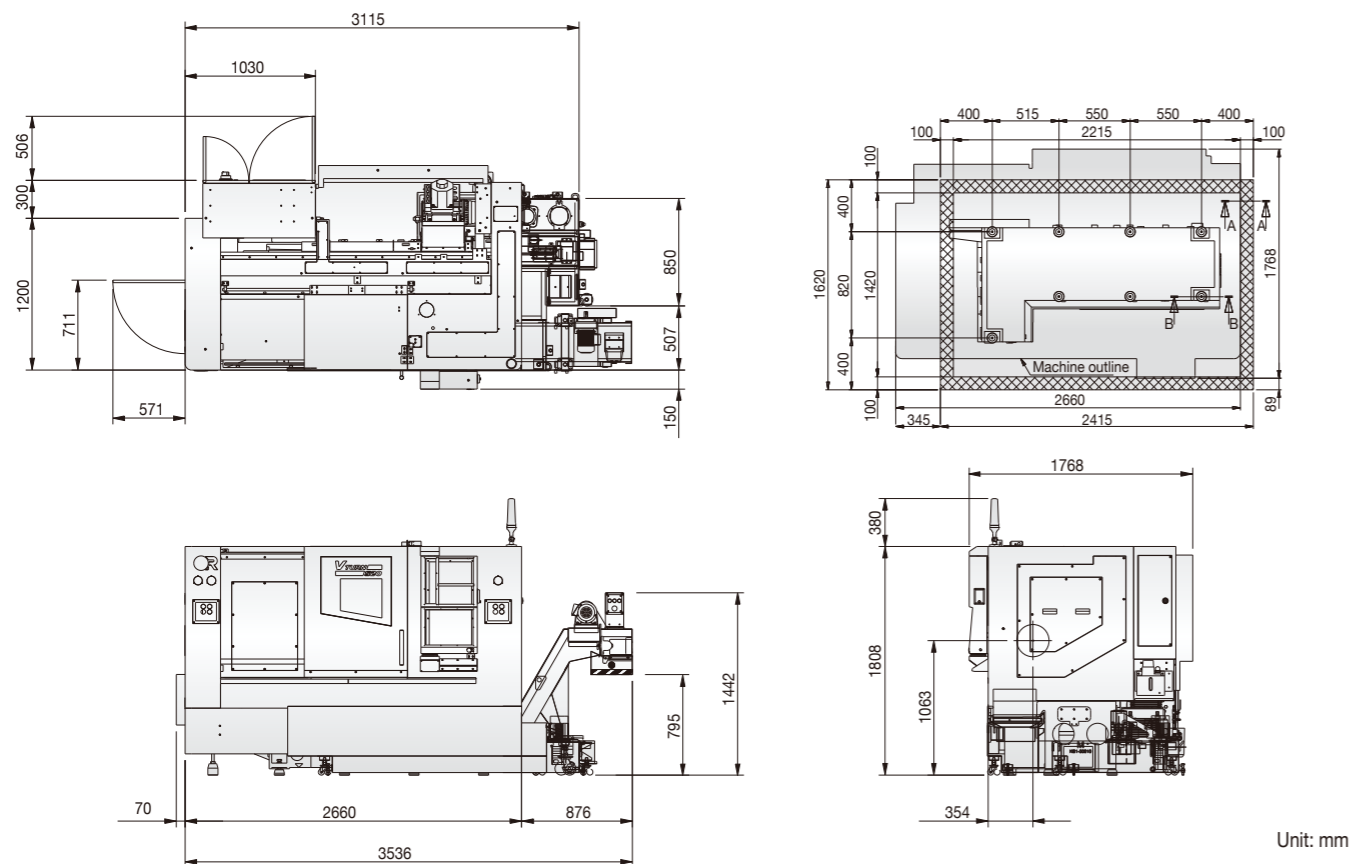

Machine Layout

Vturn-S26/60

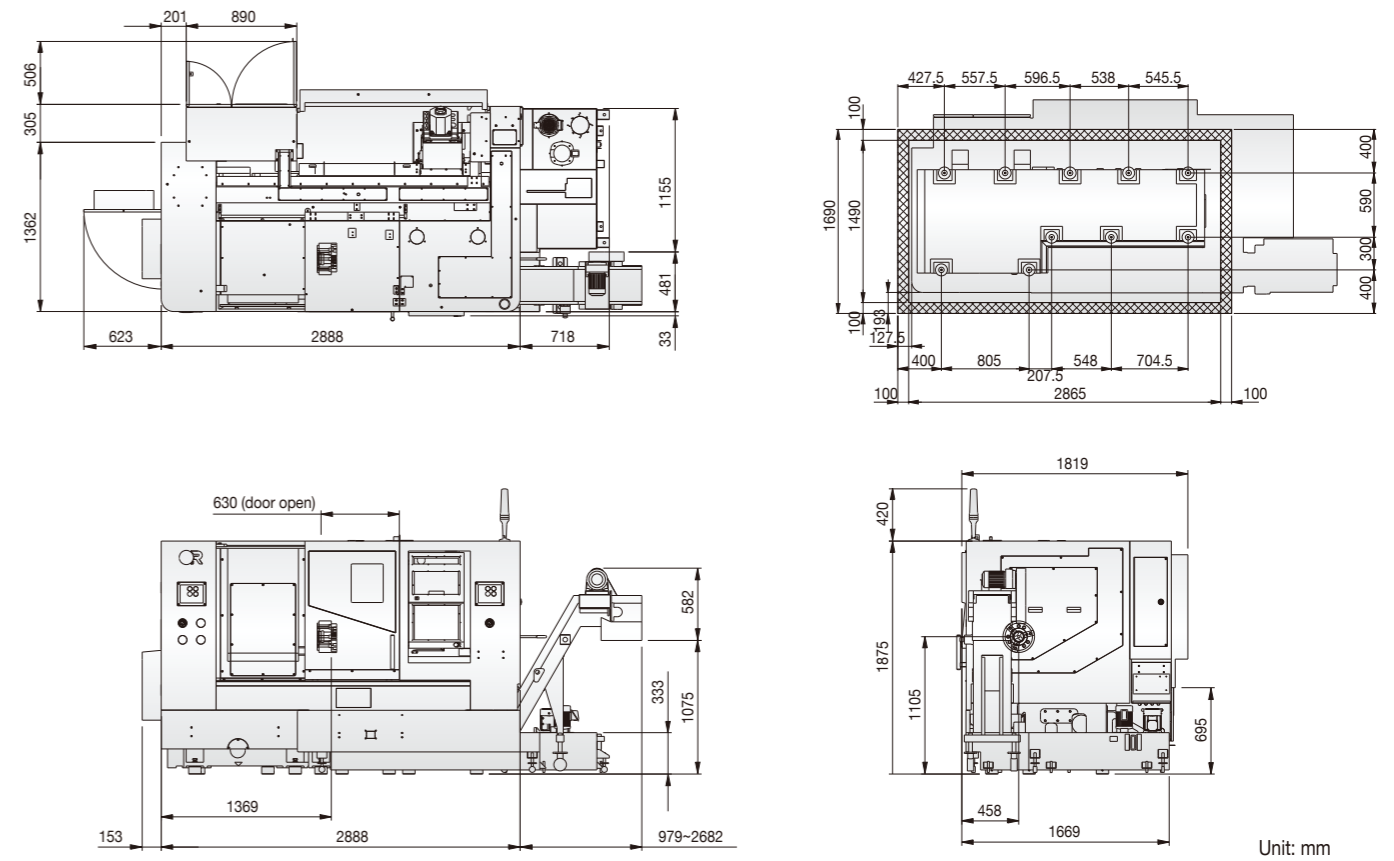

Vturn-S26/110

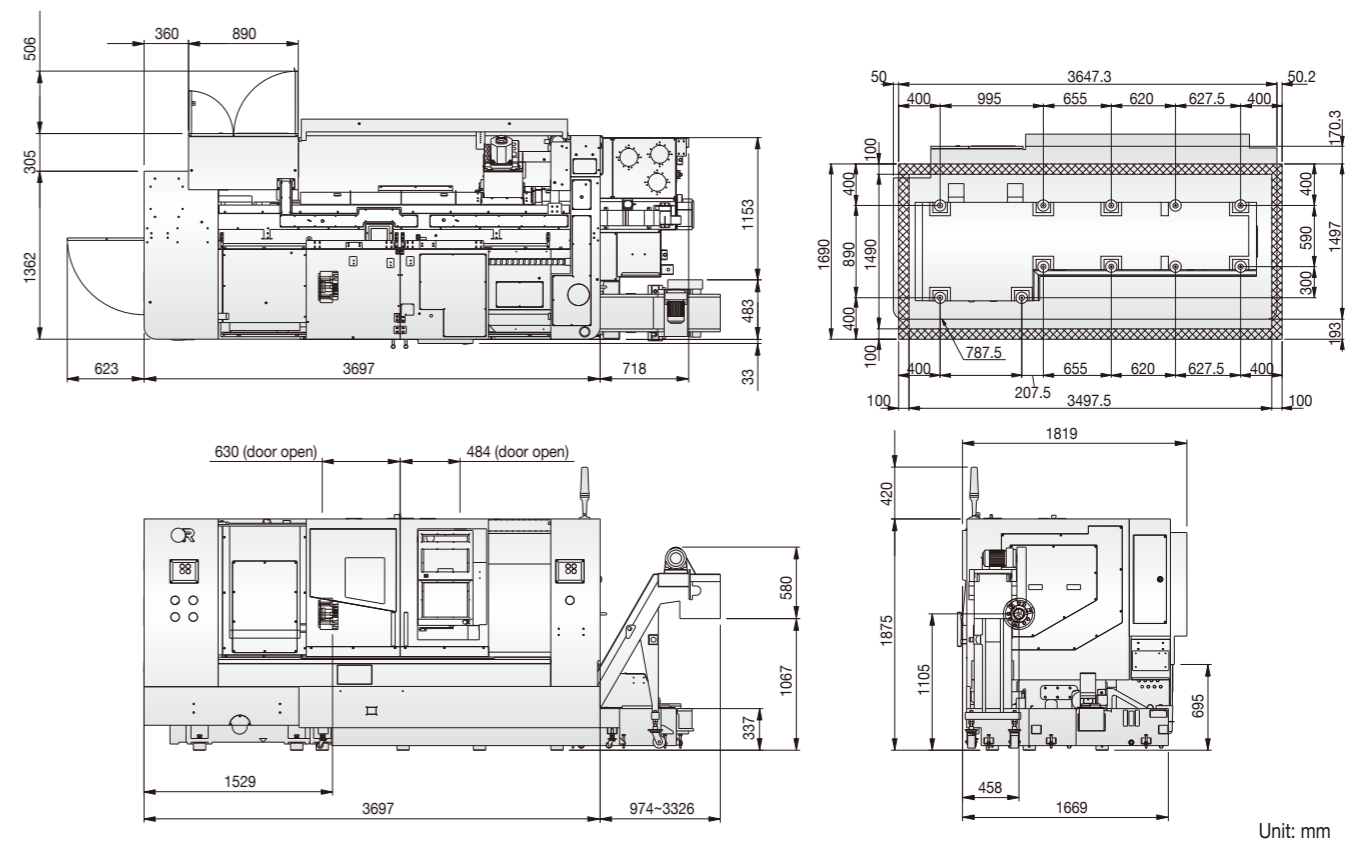

Machine Layout

Vturn-S36/85

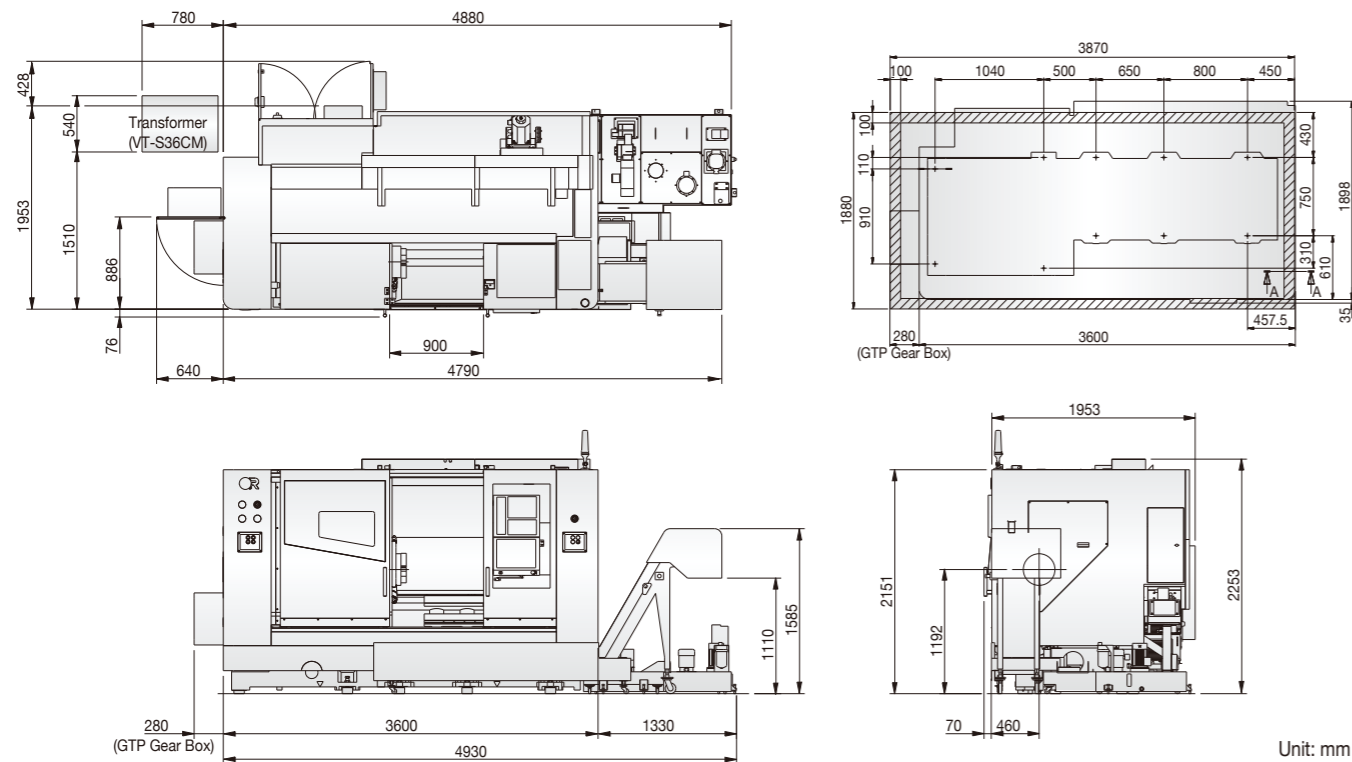

Vturn-S36/125

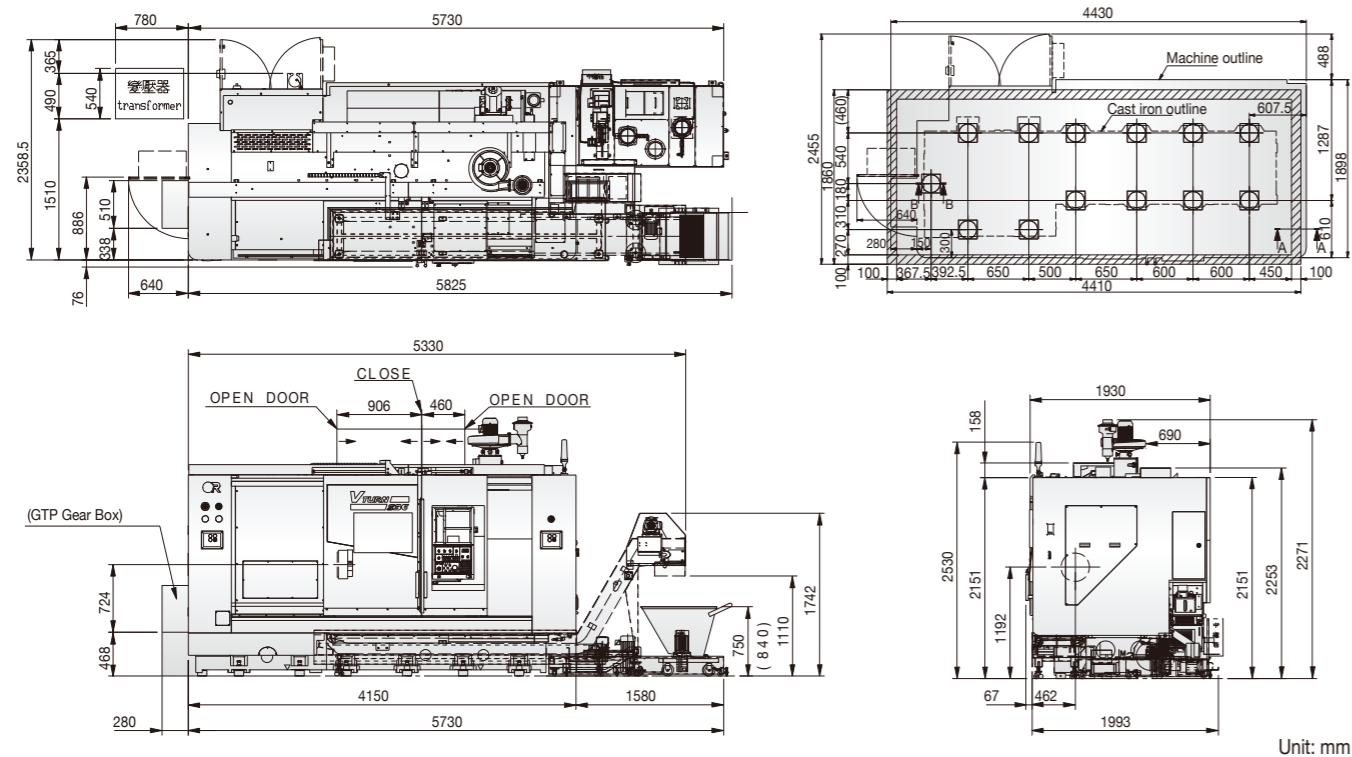

Machine Specification

Item \ Model	Unit	Vturn-S20/40 (CM) Vturn-S20/60 (CM)	Vturn-S26/60 (CM) Vturn-S26/110 (CM)	Vturn-S36/85 (CM) Vturn-S36/125 (CM)
Swing over bed dia.	mm	Ø600	Ø600	Ø780
Standard turning dia.	mm	Ø216 (Ø234)	Ø350 (Ø285)	Ø480 (Ø452)
Maximum turning dia.	mm	Ø320 (Ø260)	Ø430 (Ø420)	Ø580 (Ø580)
Swing over carriage dia.	mm	Ø430	Ø480	Ø600
Between centers	mm	420 770	640 1130	898 1298
Bar capacity (Hole thru draw bar)	mm	Ø52 (opt. 66)	Ø75 (opt. 77, 91)	Ø91 (opt. 117.5)
X axis travel	mm	160+20 (130+50)	215+25 (210+30)	290+30 (270+50)
Z axis travel	mm	400 600	610 1100	855 1255
Rapid feed - X / Z axis	m/min	20 / 24	18 / 24	18 / 20
Feed motor - X / Z axis	kW	3 / 3	3 / 4	3 / 4 (4 / 4)
JOG feed	mm/min	X/Z: 0~1260	X/Z: 0~1260	X/Z: 0~1260
Ball screw dia. x pitch	mm	Ø32 x P6 (X), Ø40 x P8 (Z)	Ø32 x P6 (X), Ø40 x P8 (Z)	Ø36 x P6 (X), Ø50 x P8 (Z)
Spindle speed	rpm	4200 (opt. 3500)	3500 (opt. 2500)	2500 (opt. 2000)
Spindle nose (chuck)	inch	A2-6 (8")	A2-8 (10")	A2-11 (12")
Spindle motor power (cont./30min/25%)	kW	7.5 / 9 / 12 (opt. 11 / 15 / 18.5)	15 / 18.5 / 22 (opt. 18.5 / 22 / 26)	22 / 26 / 35 (30 / 37 / 45)
Spindle bearing inside dia.	mm	Ø100	Ø130	Ø160
Spindle bore	mm	62 (opt. 78)	87	105 (opt. 135)
Spindle taper		1/20	1/20	1/20
No. of tools (live)		12 (12) servo	10 (12) servo	10 (12) servo
Tool shank size	mm	□25	□25	□32
Max. boring bar dia.	mm	Ø40 (BMT-55)	Ø50 (BMT-65)	Ø50 (BMT-75)
Exchange time (T-T)	sec	0.8 (0.81) - adjacent 1.0 (1.25) - opposite	0.8 (0.81) - adjacent 1.0 (1.25) - opposite	0.9 (1.36) - adjacent 1.78 (1.8) - opposite
Milling speed	rpm	4000 (opt. 6000)	4000 (opt. 6000)	3000
Milling motor	kW	2.2 (aiS 8/6000)	4.5 (aiS 22/6000)	7 (aiF 30/4000)
Tailstock quill dia.	mm	Ø75	Ø110	Ø110
Quill stroke	mm	80	100	100
Quill taper		MT #4	MT #5 (opt. MT #4)	MT #5 (opt. MT #4)
Positioning accuracy (bi-directional)	mm	0.01	0.01	0.01
Repeatability	mm	±0.004	±0.004	0.01
NC controller	Fanuc	0i-TF Plus (10.4")	0i-TF Plus (10.4")	0i-TF Plus (10.4")
Coolant tank capacity	L	250 (overflow) 220	330 380	250 (overflow type) 600
Power requirement	kVA	17 (19)	27 (29)	38 (46)
Machine dimension L x W x H (with chip conveyor)	mm	2300 x 2545 x 1848 (rear) 3536 x 1768 x 1808	4020 x 1819 x 1875 4673 x 1819 x 1875	4930 (5210) x 2029 x 2253 5480 (5760) x 2029 x 2253
Net weight (incl. std. accessories)	kgs	4800 (4860) 4800 (4860)	6050 (6150) 6650 (6750)	9000 (9100) 9850 (9950)

* Machine and controller specifications are subject to change without notice.

Standard Accessories:

- Fanuc 0i-TF Plus (10.4") with Manual Guide i
- Hydraulic chuck with soft jaws
- Programmable tailstock
- Chip conveyor (rear disposal for VT-S20/40)
- Fully enclosed splash guarding
- Hand wheel
- Tool holders (for standard turret only)
- Coolant flush on Z-axis cover
- 3 step warning light

Optional Accessories:

- Manual tool presetter
- Auto tool presetter
- Parts catcher (N.A. for VT-S36)
- KITAGAWA® power chuck
- Air conditioner for electrical cabinet (Panel cooler)
- Higher pressure coolants
- Bar feeder interface
- Air blow
- Oil skimmer
- Oil mist collector
- Auto door
- Hard jaws
- Tailstock center
- Transformer
- C-axis
- Bar stopper

VICTOR Taichung's FANUC Oi-TF Plus 10.4" Control (Type I) Specifications

Standard

ITEM/SPECIFICATION

DESCRIPTION

Controlled Axes:

1. Controlled axes	2 Axes (X, Z)
2. Simultaneous controlled axes	2 Axes
3. Least input increment	0.001mm
4. Least command increment	0.0005mm (X) / 0.001mm (Z)
5. Command system	Incremental / Absolute
6. HRV Control	HRV3+
7. Unexpected disturbance torque detection (AIR-BAG)	Std.
8. Backlash compensation	Std.
9. Stored pitch error compensation	Std.

Operation & Program Input:

1. Input / Output interface	RS-232, PCMCIA Card, USB
2. Tool offset	99 sets
3. Sequence number	N5-Digit
4. Program number	O8-Digit
5. Program name	31-characters
6. M code function	M3-digit
7. S code function	S4-digit
8. T code function	T4-digit
9. Positioning	G00
10. Linear interpolation	G01
11. Circular interpolation	G02, G03
12. Programmable data input	G10
13. Plane selection	G17-G19
14. Inch / Metric conversion	G20 / G21
15. Reference position return	G28, G30
16. Thread cutting	G32, G34
17. Threading retract	Std.
18. Tool nose radius compensation	G40-G42
19. Work piece coordinate system	G52-G59
20. Macro, Sub program call	G65, M98, M99 (10 folds nested)
21. Multiple repetitive cycle I & II	G70-G76
22. Canned cycle for drilling	G80-G89
23. Canned cycles	G90, G92, G94
24. Program stop / end	M00-M02 / M30
25. Rigid tapping (Spindle)	M29

26. Manual Guide i	Std.
27. Optional blocks skip 2-9	Std.

Feed Function:

1. Manual handle feed rate	X1, X10, X100
2. Rapid traverse rate	F0, 25%, 50%, 100%
3. Cutting feed rate	0-150%
4. Spindle override	50-120%
5. Feed per Minute / Revolution	G98 / G99

Edit Operation:

1. Part Program Storage Length (in total)	5120m (2MB)
2. Number of Registerable programs (in total)	1000
3. Part Program Editing	Std.
4. Memory card program entry count extension (Max. 1000)	Std.

C Axis Function:

1. Polar coordinate interpolation	Std. (G112/G113)
2. Cylindrical interpolation	Std. (G107)
3. CS contouring control	Std.
4. Coordinate System Rotation	Std.

Options

With hardware included

1. Tool life management	<input type="checkbox"/>
2. Program restart	<input type="checkbox"/>
3. Data server (with PCB and CF card 1GB)	<input type="checkbox"/>
4. Ethernet/IP (to be linked to robot)	<input type="checkbox"/>
5. PROFIBUS-DP (to be linked to robot)	<input type="checkbox"/>
6. CC-Link (to be linked to robot)	<input type="checkbox"/>
7. Fast Ethernet (required for SCADA Web with additional RJ45 port)	<input type="checkbox"/>

Without hardware included

8. Circular thread cutting (G35, G36)	<input type="checkbox"/>
9. AICC-1 (G5.1 Q1, 40 blocks)	<input type="checkbox"/>
10. AICC-2 (G5.1 Q1, 200 blocks)	<input type="checkbox"/>
11. Helical interpolation (C-axis only)	<input type="checkbox"/>
12. Arbitrary speed threading	<input type="checkbox"/>

Milling Motor Output

Vturn-S20CM

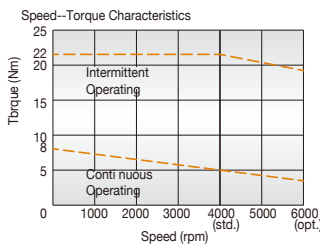

αiS 8/6000 (2.2 kW)

Vturn-S26CM

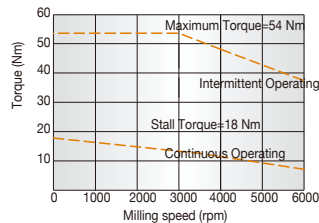

αiS 22/6000 (4.5 kW)

Vturn-S36CM

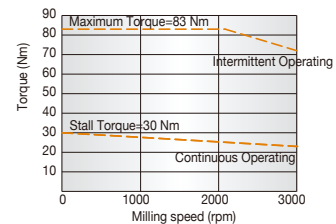

αiF 30/4000 (7 kW)



THE VICTOR-TAICHUNG COMPANIES

TAIWAN

http://www.victortaichung.com
E-mail : info@mail.or.com.tw
Victor Taichung Machinery Works Co., Ltd.
No. 1, Jingke Central 2nd Rd.,
Nantun Dist., Taichung 40852,
TAIWAN, R.O.C.
TEL : 886-4-23592101
FAX : 886-4-23593389

FRANCE

Victor France
TEL : 33-1-64772000
FAX : 33-1-64772063

GERMANY

Victor GmbH
TEL : 49-2261-478434
FAX : 49-2261-478327

SOUTH AFRICA

Victor Fortune (PTY) Ltd.
TEL : 27-11-3923800
FAX : 27-11-3923899

MALAYSIA

Victor Machinery (M) SDN. BHD.
TEL : 60-3-56337180
FAX : 60-3-56337191

THAILAND

Victor (Thailand) Co. Ltd.
TEL : 66-2-9263735
FAX : 66-2-9032373

INDONESIA

PT. Victor Machinery Indonesia
TEL : +62-21-88958504
FAX : +62-21-88958513

USA

Fortune International Inc.
TEL : 1-732-2140700
FAX : 1-732-2140701

CHINA

Victor Taichung
Machinery (Shanghai)
TEL : 86-21-59768018
FAX : 86-21-59768009



HTL



VTL



VMC



HMC



XMT



PIM