

CNC 立式車床
VERTICAL TURNING MACHINE



WVT-190 SERIES

產線持續優化

窄面寬，配置靈活，智慧製造的最佳幫手

CONTINUOUS OPTIMIZATION OF PRODUCTION LINE
NARROW FACE WIDTH. FLEXIBLE LAYOUT.
YOUR BEST PARTNER IN INTELLIGENT
MANUFACTURING.

超窄面寬

不只可減少操作者移動空間，加快生產節拍，並且大幅縮減佔地面積，提升廠方使用率。

Narrow Face Width

The compact structure of the machine reduces operator's movement range, increases production speed, dramatically reduces space occupation, and increases the utilization of the factory area.



高剛性主軸

可依客戶需求搭配A2-6 或A2-8 主軸，並且採用高強度兩端支撐結合底座，確保主軸剛性，提升加工性能。

Highly Rigid Spindle

Depending on customer's request, this machine can be equipped with an A2-6 or A2-8 spindle. The spindle is firmly supported at both ends in combination with the stable base to ensure spindle rigidity, leading to higher machining performance.



專利複合式刀塔

同時改善櫛式刀塔不利於複雜工序的缺點；並改善塔式刀塔，換刀時程久的缺點。兼具速度與刀具容量。

Patented Complex Tool Turret

This turret is exclusively designed to overcome the disadvantages of complicated processes conducted by using a gang type turret. In addition, defects of time-consuming tool change on conventional tool turrets are improved as well. The specially designed turret features improved tool moving speed and tool capacity.



自動工件交換機構（選配）

備有可程式自動上下料功能，增加有效加工時間，大幅提升產出效率，並達成省人化及單機自動化。

Automatic Workpiece Changer (optional)

The programmable automatic workpiece loading/unloading function increases effective machining time to dramatically upgrade production efficiency. It also meets the requirements for labor-saving and single machine automation.

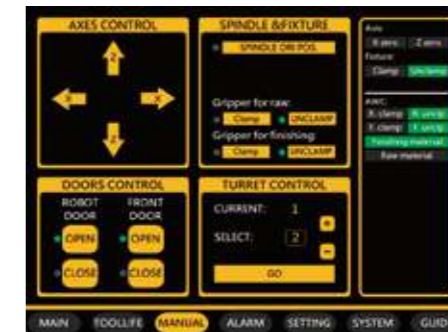

智慧生產-人機介面

- 為大數據應用超前部署，操作箱設置觸控螢幕，操作直覺，學習曲線短。
- 可將單機訊號與生產線廣播訊息即時顯示，並可額外增加客制需求功能的操作介面，提升工廠可視化。
- 可進階做出圖形監控、簡化故障排除步驟；以及設置不同現場SOP提示頁面，防止操作錯誤。

Intelligent Production through Human-Machine Interface

- The intelligent production system provides an advanced deployment for big data applications in the future. The control box is equipped with a touchscreen for intuitive operation and shortening learning time.
- The signals of a single machine and the information of production line are displayed in real time. The operational interface can use customized functions, helping to increase factory visualization.
- The use of advanced graphic monitoring allows for simplifying troubleshooting procedures. It also provides SOP hint displays at the work site to avoid operation error.

彈性配置各式生產

- 可單機或多機配置。
- 可與六軸機械手搭配應用，亦可多加承料盤。
- 可與桁架式機械手做多製程自動化配置。

Flexible Layout to Suit Various Production Requirements

- Single machine operation or multi-machine combination.
- Can be used together with a 6-axis robot or workpiece tray.
- Multi-process automation can be achieved through the use of gantry type parts loaders.

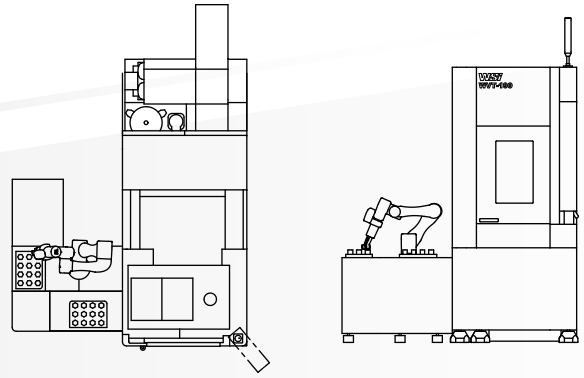

自動工件交換台加配機械手配置示意

Layout drawings of part changer and robot



週邊配備

俾詳可依照客戶工件需求，客製周邊入料、中轉以及出料站。

Peripheral Equipment

WSI also offers various peripheral equipment according to customers' workpieces, such as part infeed, transfer, and outfeed stations.



70 Bar 高壓中心出水 (選配)

本機可依客戶加工需求，加裝高壓中心出水裝置。WSI 整合式水箱可多段切換壓力，使機器大幅提升加工速度，進而提高產能。高穩定的泵浦可降低刀具磨耗，延長刀具使用壽命，可解決切屑纏繞問題，以及提高工件加工之精度。搭配超大容量濾罐，確保切削液的潔淨。

70 Bar High Pressure Coolant Through Center (optional)

Upon customer's request, this machine is available to equip with a high pressure coolant through center device. WSI's integrated coolant tank provides various pressure changes, enabling the machine to boost machining speed resulting in higher productivity. The constant pressure pump with high stability reduces tool wear, extends tool life, solves the problem of chip winding and upgrades workpiece accuracy. With the use of large capacity filter to ensure the cleanliness of coolant.

主軸扭力圖 Spindle Power & Torque Diagram

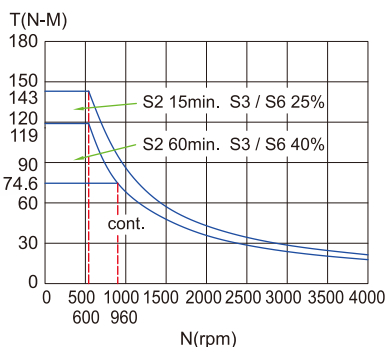
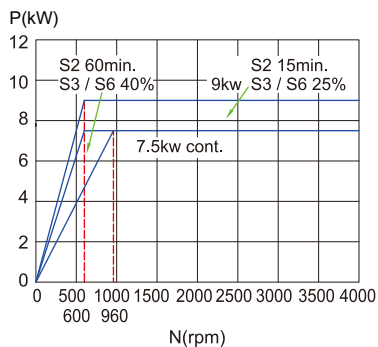
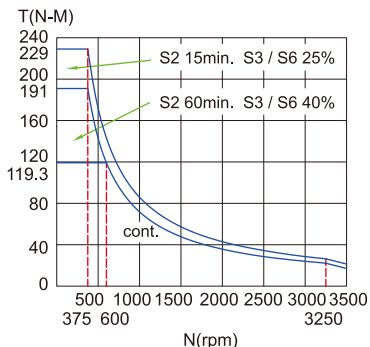
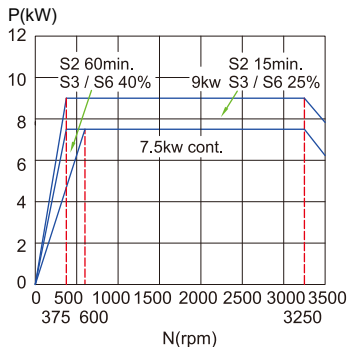
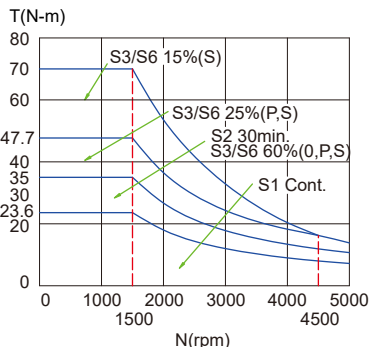
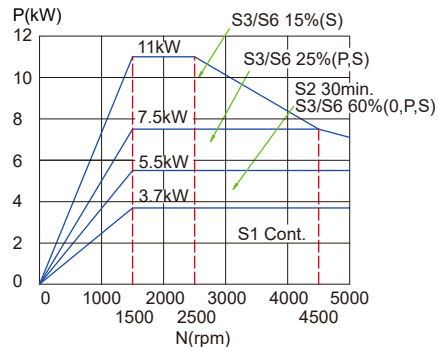
WVT-190 APC
4,000 rpm

WVT-190M
3,500 rpm

WVT-190M
刀具主軸 Live Tool
5,000 rpm

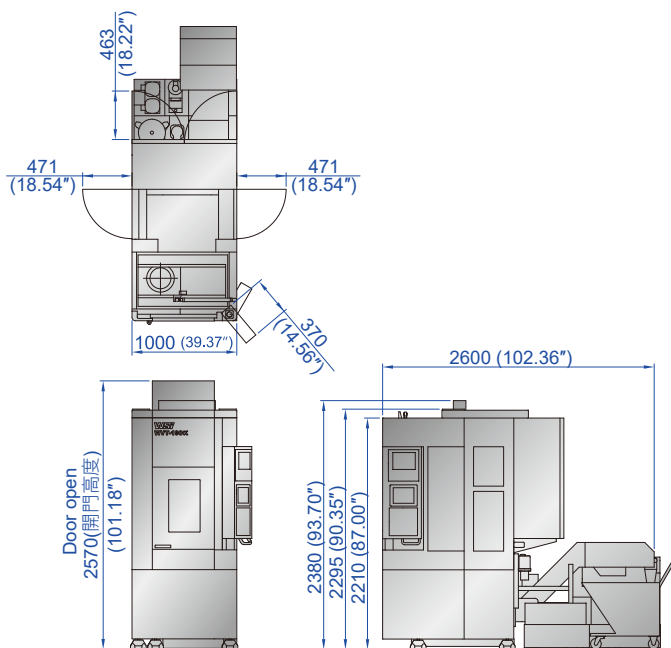
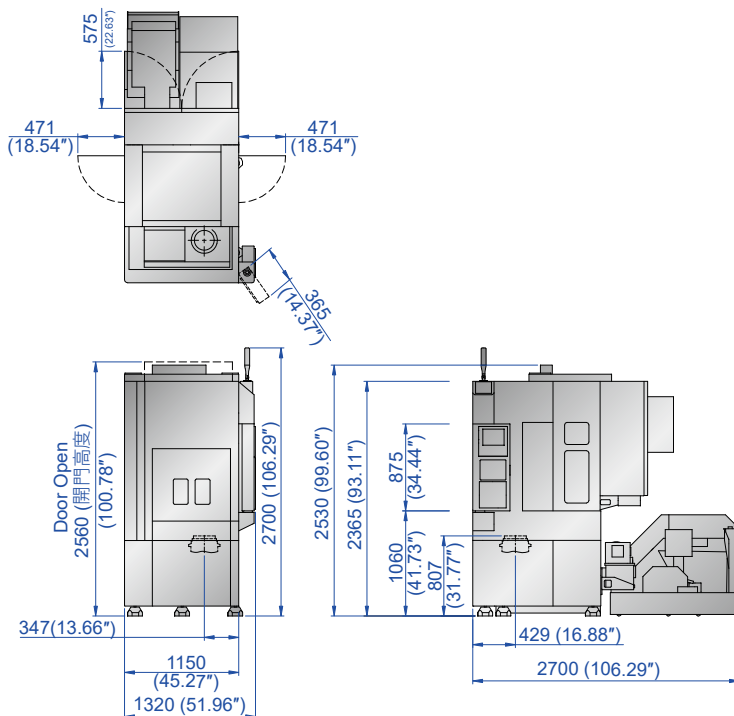
外觀尺寸圖 Machine Dimensions

單位 Unit: mm/inch

WVT-190
WVT-190K

WVT-190M

刀具干涉與加工範圍圖 Tool Interference Diagram & Working Area

單位 Unit: mm/inch

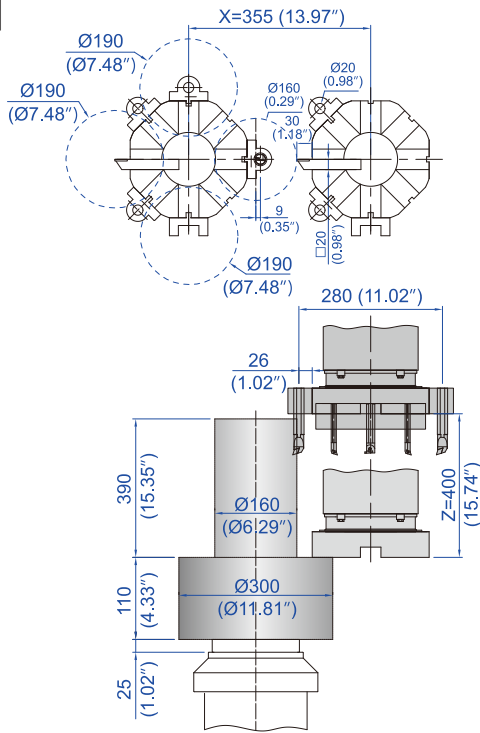
WVT-190
8T



WVT-190 APC
8T
APC 行程範圍

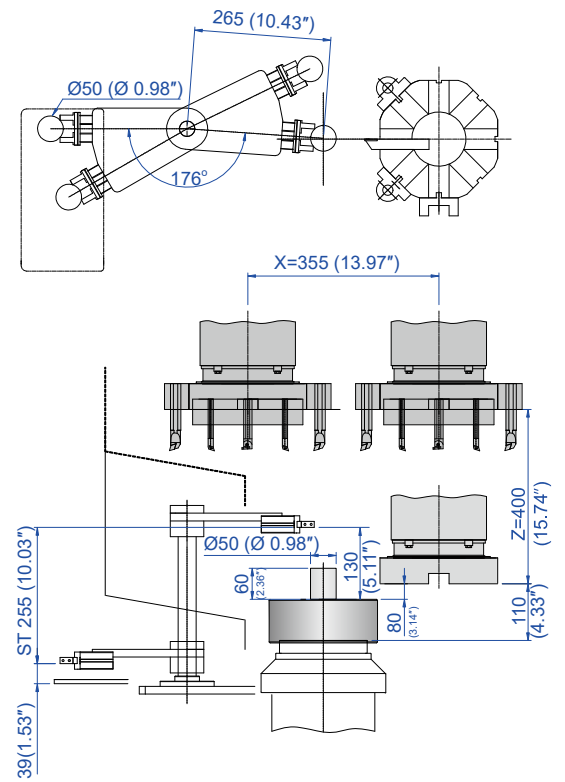

WVT-190K
10T

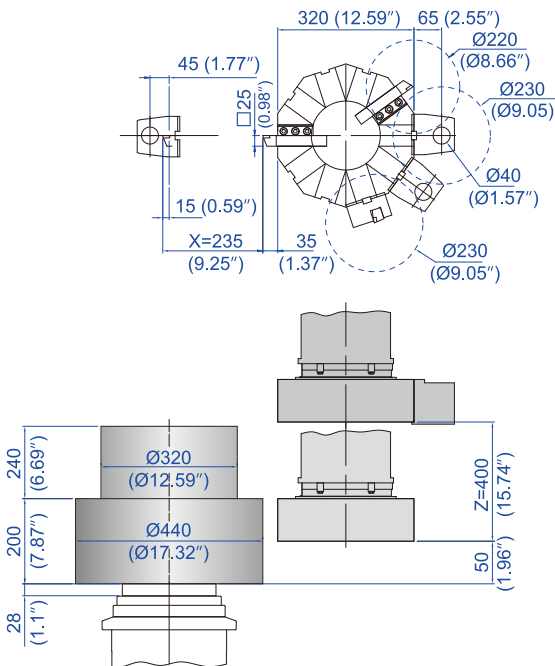

WVT-190M
12T
VDI 40

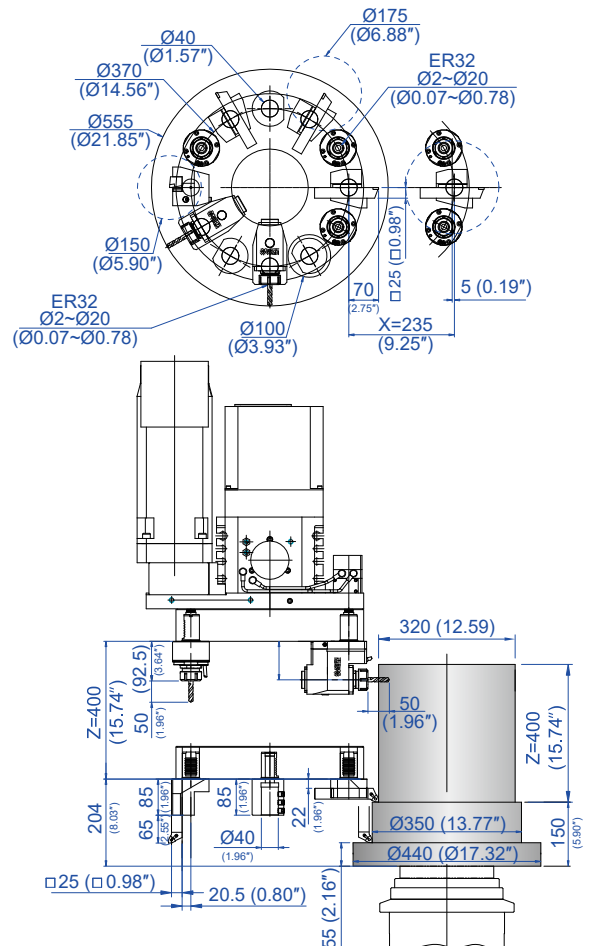

刀具系統 Tooling System

WVT-190 專利複合櫛式刀塔
8T

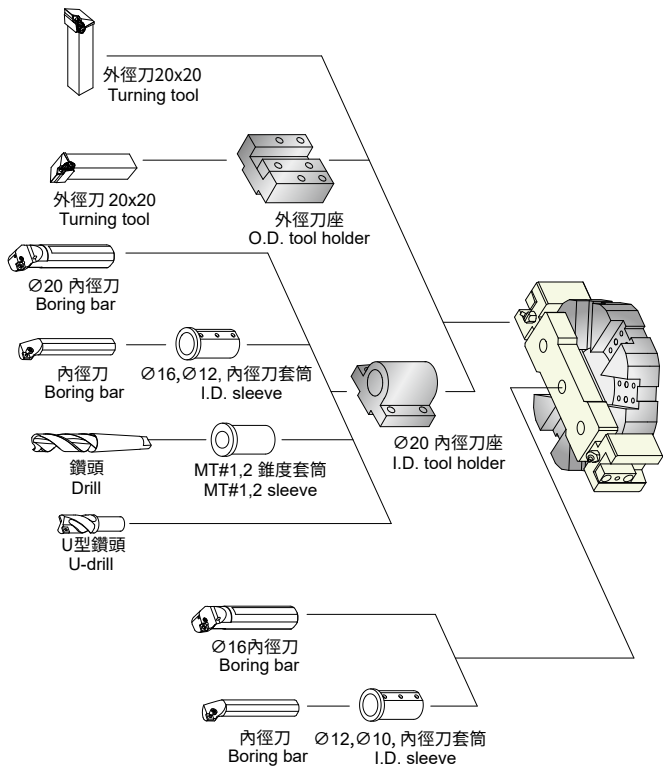

WVT-190K
10T

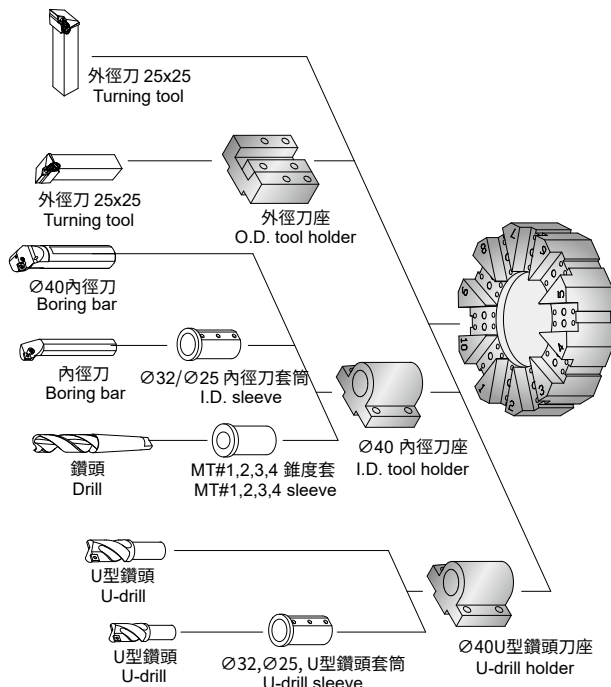

WVT-190M
12T

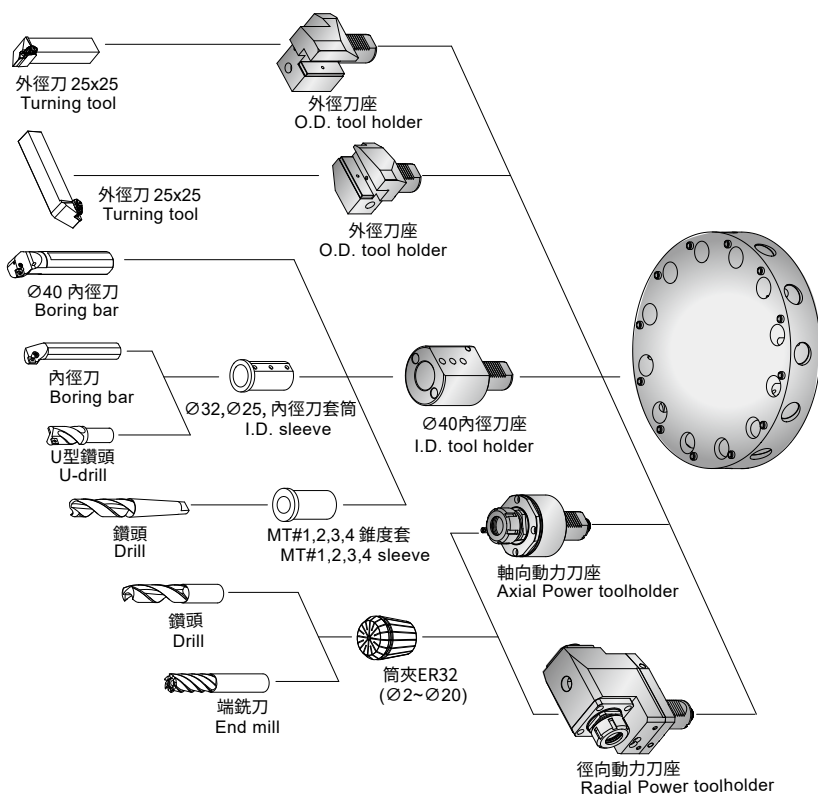

刀柄規格：DIN5480 W20x0.8
AND ZERO DETENT SYSTEM

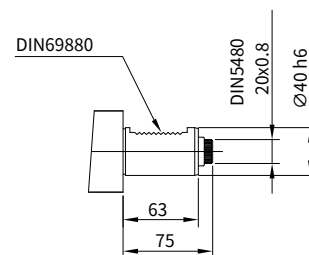

規格表 Machine Specifications

機 型	MODEL	WVT-190	WVT-190K	WVT-190M
加工功能	Capacity			
最大旋徑	Max. swing	Ø300 mm (Ø11.81")	Ø440 mm (Ø17.32")	Ø440 mm (Ø17.32")
過十字座最大車削直徑	Max. turning diameter over cross slide	-	Ø320 mm (Ø12.59")	Ø320 mm (Ø12.59")
最大車削直徑	Max. turning diameter	Ø160 mm (Ø6.29")	Ø440 mm (Ø17.32")	Ø350 mm (Ø13.77")
最大車削高度	Max. turning height	500 mm (16.92")	440 mm (14.56")	550 mm (21.65")
主軸	Spindle			
主軸轉速	Max. spindle speed	4,000 rpm	3,500 rpm	3,500 rpm
主軸軸承內徑	Inside dia. of spindle bearing	Ø100 mm (Ø3.93")	Ø130 mm (Ø5.11")	Ø130 mm (Ø5.11")
主軸鼻端	Spindle nose	A2-6	A2-8	A2-8
夾頭尺寸	Chuck size	8"	10"	10"
行程	Travel			
X軸行程	X-axis travel	355 mm (13.97")	235 mm (9.25")	235 mm (9.25")
Z軸行程	Z-axis travel	400 mm (11.02")	400 mm (11.02")	400 mm (11.02")
進給	Feed			
X軸快速進給	Rapid traverse on X-axis	30 m/min (1.18 ipm)	30 m/min (1.18 ipm)	30 m/min (1.18 ipm)
Z軸快速進給	Rapid traverse on Z-axis	20 m/min (0.78 ipm)	20 m/min (0.78 ipm)	30 m/min (1.18 ipm)
馬達	Motor			
主軸馬達	Spindle motor	7.5/9 Kw (10/12 HP)	7.5/9 Kw (10/12 HP)	7.5/9 Kw (10/12 HP)
X軸伺服馬達	X-axis servo motor	1.2 Kw (1.6 HP)	1.2 Kw (1.6 HP)	1.2 Kw (1.6 HP)
Z軸伺服馬達	Z-axis servo motor	1.4 Kw (1.88 HP)	1.4 Kw (1.88 HP)	3.0 Kw (4.08 HP)
油壓泵浦馬達	Hydraulic pump motor	1.5 Kw (2 HP)	1.5 Kw (2 HP)	1.5 Kw (2 HP)
切削水馬達	Coolant motor	0.55 Kw (0.73 HP)	0.55 Kw (0.73 HP)	0.55 Kw (0.73 HP)
刀塔	Turret			
刀塔型式	Turret type	專利複合櫥式刀塔 Patented gang type turret	油壓伺服刀塔 Hydraulic servo turret	動力刀塔 Power turret
刀具數	No. of tools	8T	10T	12T
外徑刀尺寸	O.D. tool size	□20 mm (0.78")	□25 mm (0.98")	□25 mm (0.98")
內徑刀尺寸	I.D. tool size	Ø20 / Ø16 mm (Ø0.78" / Ø0.62")	Ø40 mm (Ø1.57")	Ø40 mm (Ø1.57")
換刀時間 (相鄰刀)	Tool change time (adjacent tool)	0.48 sec	0.48 sec	0.42 sec
外型尺寸	Outline Dimensions			
長x寬x高	L x W x H	2,850 x 1,000 x 2,615 mm (112.2" x 39.37" x 102.95")	3,400 kg (7,500lb)	2,700 x 1,300 x 2,700 mm (106.29" x 51.18" x 106.29")
重量	Weight	3,200 kg (7,055lb)	3,400 kg (7,500lb)	3,800 kg (7,500lb)

● 本公司保留產品規格、外觀、配備變更或停用之權利。

● We reserve the rights to change the product specifications, appearance, accessories or advise no longer in use.

標準配備

- 鐵屑輸送機
- 熱交換器
- LED警示燈
- 智慧人機介面
- 全密鈹金
- 工作燈
- MPG手輪
- 刀塔切削水裝置
- 自動潤滑泵浦
- 操作者自動門
- 控制器Fanuc OiT

選配配備

- WHU智能高壓油站
- 節能油箱
- 自動工件交換機構
- 油霧回收機
- 工件量測系統
- 刀具量測系統
- 工件氣密檢知(Festo SOPA)
- 刀具壽命管理系統
- 油水分離機
- 高壓中心出水70bar
- 電控箱冷氣
- LUBE自動潤滑系統
- 動力刀塔

Standard Equipment

- Chip conveyor
- Heat exchanger
- LED alarm lamp
- Intelligent human-machine interface
- Fully enclosed splash guard
- Work light
- MPG handwheel
- Coolant device for turret
- Auto lubrication pump
- Auto door for operator
- FANUC OiT controller

Optional Equipment

- WHU intelligent high pressure hydraulic system
- Energy saving hydraulic system
- Automatic workpiece changer
- Oil mist collector
- Workpiece measurement system
- Tool measurement system
- Air gap sensor for workpiece (Festo SOPA)
- Tool life management system
- Oil skimmer
- High pressure coolant through center 70 bar
- Air conditioner for electrical cabinet
- Automatic lubrication system
- Power turret

WSI 偉詳工業股份有限公司
WAYSIA Industrial Co., Ltd.

嘉義縣民雄工業區中興一街6號
6, Chung Hsing 1st Street,
Ming Hsiung Industrial Area, Chiayi, Taiwan
Tel: 886-5-2210485 Fax: 886-5-2210219
www.waysia.com
E-mail: sales@waysia.com

